

AKAI

SERVICE MANUAL





Model: PDP4273M

1

1. Safety Precaution	2~3
2. Technical Specifications.....	4~10
3. Circuit Diagram.....	11~33
4. Basic Operations & Circuit Description.....	34~36
5. Main IC Information.....	37
6. Panel Information.....	38~67
7. Spare Pare List.....	68~71
8. Exploded View.....	72
9. If you forget your V-Chip Password.....	73
10. Software Upgrade.....	74~82

.....
This manual is the latest at the time of printing, and does not
include the modification which may be made after the printing,
by the constant improvement of product.
.....

Safety Precaution

  <p>CAUTION RISK OF ELECTRIC SHOCK DO NOT OPEN</p> <p>CAUTION: TO REDUCE THE RISK OF ELECTRIC SHOCK, DO NOT REMOVE COVER (OR BACK). NO USER-SERVICEABLE PARTS INSIDE. REFER SERVICING TO QUALIFIED SERVICE PERSONNEL ONLY.</p>	 <p>The lightning flash with arrowhead symbol, within an equilateral triangle, is intended to alert the user to the presence of uninsulated "dangerous voltage" within the product's enclosure that may be of sufficient magnitude to constitute a risk of electric shock to persons.</p>
	 <p>The exclamation point within an equilateral triangle is intended to alert the user to the presence of important operating and maintenance (servicing) instructions in the literature accompanying the appliance.</p>

PRECAUTIONS DURING SERVICING

1. In addition to safety, other parts and assemblies are specified for conformance with such regulations as those applying to spurious radiation. These must also be replaced only with specified replacements.
Examples: RF converters, tuner units, antenna selection switches, RF cables, noise-blocking capacitors, noise-blocking filters, etc.
2. Use specified internal Wiring. Note especially:
 - 1) Wires covered with PVC tubing
 - 2) Double insulated wires
 - 3) High voltage leads
3. Use specified insulating materials for hazardous live parts. Note especially:
 - 1) Insulating Tape
 - 2) PVC tubing
 - 3) Spacers (insulating barriers)
 - 4) Insulating sheets for transistors
 - 5) Plastic screws for fixing micro switches
4. When replacing AC primary side components (transformers, power cords, noise blocking capacitors, etc.), wrap ends of wires securely about the terminals before soldering.

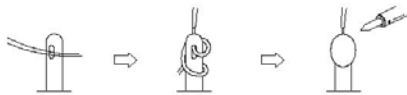

5. Make sure that wires do not contact heat generating parts (heat sinks, oxide metal film resistors, fusible resistors, etc.)
6. Check if replaced wires do not contact sharply edged or pointed parts.
7. Make sure that foreign objects (screws, solder droplets, etc.) do not remain inside the set.

MAKE YOUR CONTRIBUTION TO PROTECT THE ENVIRONMENT

Used batteries with the ISO symbol 

for recycling as well as small accumulators (rechargeable batteries), mini-batteries (cells) and starter batteries should not be thrown into the garbage can.

Please leave them at an appropriate depot.

WARNING:

Before servicing this TV receiver, read the SAFETY INSTRUCTION and PRODUCT SAFETY NOTICE.

SAFETY INSTRUCTION

The service should not be attempted by anyone unfamiliar with the necessary instructions on this apparatus. The following are the necessary instructions to be observed before servicing.

1. An isolation transformer should be connected in the power line between the receiver and the AC line when a service is performed on the primary of the converter transformer of the set.
2. Comply with all caution and safety related provided on the back of the cabinet, inside the cabinet, on the chassis or picture tube.
3. To avoid a shock hazard, always discharge the picture tube's anode to the chassis ground before removing the anode cap.
4. Completely discharge the high potential voltage of the picture tube before handling. The picture tube is a vacuum and if broken, the glass will explode.

5. When replacing a MAIN PCB in the cabinet, always be certain that all protective are installed properly such as control knobs, adjustment covers or shields, barriers, isolation resistor networks etc.
6. When servicing is required, observe the original lead dressing. Extra precaution should be given to assure correct lead dressing in the high voltage area.
7. Keep wires away from high voltage or high tempera ture components.
8. Before returning the set to the customer, always perform an AC leakage current check on the exposed metallic parts of the cabinet, such as antennas, terminals, screwheads,metal overlay, control shafts, etc., to be sure the set is safe to operate without danger of electrical shock. Plug the AC line cord directly to the AC outlet (do not use a line isolation transformer during this check). Use an AC voltmeter having 5K ohms volt sensitivity or more in the following manner.

Connect a 1.5K ohm 10 watt resistor paralleled by a 0.15 μ F AC type capacitor, between a good earth ground (water pipe, conductor etc.,) and the exposed metallic parts, one at a time. Measure the AC voltage across the combination of the 1.5K ohm resistor and 0.15 μ F capacitor. Reverse the AC plug at the AC outlet and repeat the AC voltage measurements for each exposed metallic part.

The measured voltage must not exceed 0.3V RMS.

This corresponds to 0.5mA AC. Any value exceeding this limit constitutes a potential shock hazard and must be corrected immediately.

The resistance measurement should be done between accessible exposed metal parts and power cord plug prongs with the power switch "ON". The resistance should be more than 6M ohms.

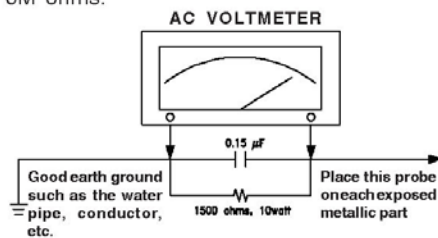

PRODUCT SAFETY NOTICE

Many electrical and mechanical parts in this apparatus have special safety-related characteristics.

These characteristics are offer passed unnoticed by visual spection and the protection afforded by them cannot necessarily be obtained by using replacement components rates for a higher voltage, wattage, etc.

The replacement parts which have these special safety characteristics are identified by Δ marks on the schematic diagram and on the parts list.

Before replacing any of these components, read the parts list in this manual carefully. The use of substitute replacement parts which do not have the same safety characteristics as specified in the parts list may create shock, fire, or other hazards.

9. Must be sure that the ground wire of the AC inlet is connected with the ground of the apparatus properly.

1. Standard Test Conditions

All tests shall be performed under the following conditions, unless otherwise specified.

- 1.1 Ambient light : 150ux (When measuring I_B , the ambient luminance $\leq 0.1\text{Cd/m}^2$)
- 1.2 Viewing distance : 50cm in front of PDP
- 1.3 Warm up time : 30 minutes
- 1.4 PDP Panel facing : no restricted
- 1.5 Measuring Equipment : Minolta CA 100 photometer
- 1.6 Magnetic field : no restricted
- 1.7 Control settings : Brightness, Contrast, Tint, Color set at Center(50)
- 1.8 Power input : 120Vac, 60Hz
- 1.9 Ambient temperature : $20^\circ\text{C} \pm 5^\circ\text{C}$ ($68^\circ\text{F} \pm 9^\circ\text{F}$)
- 1.10 Display mode : Resolution 1024 (H) x 1024 (V) Pixels
- 1.11 Other conditions :
 - 1.11.1 With image sticking protection of PDP module, the luminance will descend by time on a same still screen and rapidly go down in 5 minutes. When measuring the color tracking and luminance of a same still screen, be sure to accomplish the measurement in one minute to ensure its accuracy.
 - 1.11.2 Due to the structure of PDP, the extra-high-bright same screen should not hold over 5 minutes for fear of branding on the panel.

<u>ELECTRICAL CHARACTERISTICS</u>	
2. Power Input	
2.1 <u>Voltage</u>	: 120VAC
2.2 <u>Input Current</u>	: 3.0A
2.3 <u>Maximum Inrush Current</u>	: <30 A (FOR AC 120V ONLY)
Test condition	: Measured when switched off for at least 20 mins
2.4 <u>Frequency</u>	: 60Hz(±3Hz)
2.5 <u>Power Consumption</u>	: 330W Typical
Test condition	: full white display with maximum brightness and contrast
2.6 <u>Power Factor</u>	: Meets IEC1000-3-2
2.7 <u>Withstanding voltage</u>	: 1.5kVac or 2.2kVdc for 1 sec
3. Display	
3.1 Screen Size	: 42" Plasma display
3.2 Aspect Ratio	: 16:9
3.3 Pixel Resolution	: 1024 x 768
3.4 Peak Brightness	: 1200 cd/m ² (Panel module without filter)
3.5 Contrast Ratio (Dark room)	: 10000:1 (Panel module without filter)
3.6 Viewing Angle	: Over 160°
3.7 OSD language	: English, Spanish, French
4. Signal	
4.1 <u>AV & Graphic input</u>	
4.1.1 Composite signal	: AV
4.1.2 Y,C Signal	: S-Video
4.1.3 Component signal	: YPbPr HDTV compatible
4.1.4 Graphic Input	: D-Sub 15 pin detachable cable
4.1.5 HDMI	: HDMI
4.1.6 PnP compatibility	: DDC 1.0
4.1.7 I/P frequency	: f _H : 31.5kHz to 60kHz/f _V : 56.25Hz to 75Hz (640x480 recommended)

- 4.2 Audio input
 Audio Input(L/Rx5) : 1 for DVI / D-Sub
 2 for YPbPr
 1 for S-Video
 1 for AV

- 4.3 Audio output
 Audio Output (L/Rx1) : Monitor out(L/R)
 SPDIF : Coaxial x 1 (only for HDMI)

5. Environment

- 5.1 Operating environment
 5.1.1 Temperature : 5° to 33°C
 5.1.2 Relative humidity: 20% to 85%(non-condensing)

- 5.2 Storage and Transport
 5.2.1 Temperature : -20°C to 60°C (-4° to 140°F)
 5.2.2 Relative humidity: 5% to 95%

6. Panel Characteristics

- 6.1 Type : 42LGX3
 6.2 Size : 1005(H)x597(V)x60.7(D)±1mm
 6.3 Aspect ratio : 16:9
 6.4 Viewing angle : Over 160°
 6.5 Resolution : 1024 x 168
 6.6 Weight : Approx 16kg
 6.7 Color : 1073.7 million colors by combination of 10 bits R,G,B digital
 6.8 Contrast : 10000:1, Peak White, display rate: 1%, In dark room.
 6.9 Peak brightness : 1200cd/m², Peak White, Max. gradation, display rate: 1%.

- 6.10 Color Coordinate Uniformity : Contrast; Brightness and Color control
 at normal setting
 Test Pattern : Full white pattern

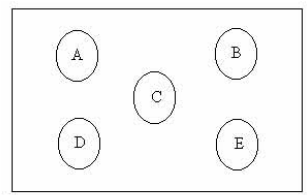

Average of point A,B,C,D and E +/- 0.01

6.11 Color temperature : Contrast and Brightness at Normal;
 Colortemperature set at Middle
 $x=0.285\pm0.02$
 $y=0.293\pm0.02$

6.12 Cell Defect Specifications
 Subject to Panel supplier specification as appends.

7. Front Panel Control Button

- 7.1 SEL. Up / Down Button : Select the up or down item in OSD menu.
- VOL. Left / Right Button : Press the key to increase the volume left or right.
 When selecting the adjusting item on OSD menu
 increase or decrease the data-bar.
- MENU Button : Press the key to display or exit the menu.
- SOURCE Button : Press the key to select the input signals source.
- 7.2 STANDBY Button : Switch on main power, or switch off to enter power
 Saving modes.
- 7.3 Main Power Switch : Turn on or off the unit.

8. OSD Function

Full on screen display

9. Agency Approvals

Safety UL60950
 Emissions FCC class B

10. Reliability

10.1 MTBF: 20,000 hours (Use moving picture signal at 25°C ambient)

11. Accessories: User Manual x 1, Remote Control x 1, Stand x 1, Power Cord x 1, Battery x2.

12 Remote Control

- ① **Standby(⏻)**: Press this button to turn off to standby and turn on from standby.
- ② **Mute(🔇)**: Press this button to quiet the sound system. Press again to reactivate the sound system.
- ③ **Number buttons**: Use these buttons to enter the password.
- ④ **Source**: Press this button to select the signal sources. AV, S-Video, YPbPr 1, YPbPr 2, VGA or HDMI.
- ⑤ **Sleep**: Press this button to select the sleep time, such as "15 Min, 30 Min, 60 Min, 90 Min, 120 Min or off".
- ⑥ **VOL +/-** : Press these buttons to increase or decrease the volume.
- ⑦ **P. Mode** : Press the button to select different picture effect, such as "Normal, Vivid, Hi-Bright, User or Cinema".
- ⑧ **System**: Press this button to select the color system, such as "AUTO or NTSC 3.58". (Only for AV or S-Video)
- ⑨ These buttons have no function. Pressing the button will display: "This button is not in use."
- ⑩ **Enter** : Press to enter or confirm.
 ◀ / ▶ : They are used as ◀ / ▶ buttons in the OSD Menu screen.
 ▲ / ▼ : They are used as ▲ / ▼ buttons in the OSD Menu screen.
- ⑪ **Exit**: Press this button to exit the OSD Menu.
- ⑫ **Menu**: Press this button to pop up the OSD Menu and press it again to exit the OSD Menu.
- ⑬ **Freeze**: Press this button to hold on the screen. Press again to normal.
- ⑭ **Display**: Press the button to display the source information.
- ⑮ **S. Mode**: Press the button to select different sound effect, such as "Normal, News, Cinema, Concert or User".
- ⑯ **V-Chip**: Press this button to enter the V-Chip Function. (Only for AV or S-Video)
- ⑰ **P. Size**: Press this button, the picture will change according to Full, 4:3 or Panoramic. (inactive for VGA)
- ⑱ **C/C**: Press this button to enter the Closed Caption Function. (Only for AV or S-Video)

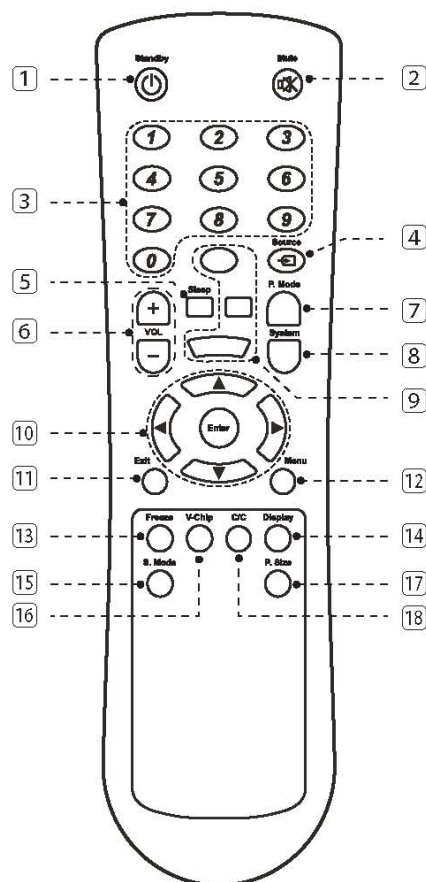

13. Support the Signal Mode

A. VGA Mode

Resolution	Horizontal Frequency (KHz)	Vertical Frequency (Hz)
640 x 480	31.50	60.00
	37.86	72.81
800 x 600	35.16	56.25
	37.90	60.32
	46.90	75.00
1024 x 768	48.08	72.19
	48.40	60.00

B.YPbPr Mode

Resolution	Horizontal Frequency (KHz)	Vertical Frequency (Hz)
480i	15.734	59.94
480p(720x480)	31.468	59.94
720p(1280x720)	45.00	60.00
1080i(1920x1080)	33.75	60.00

C.HDMI Mode

Resolution	Horizontal Frequency (KHz)	Vertical Frequency (Hz)
480p	31.468	59.94
720p	45.00	60.00
1080i	33.75	60.00

- When the signal received by the Display exceeds the allowed range, a warning message shall appear on the screen.
- You can confirm the input signal format from the on-screen.

PHYSICAL CHARACTERISTICS

14. Power Cord

Length : 1.8m nominal
 Type : optional

15. Cabinet

15.1 Color : "Black" colour as defined by colour plaque reference number

15.2 Weight

Net weight : 35.5 kg(with stand, speaker and handles)
 Gross weight : 41.6 kg

15.3 Dimensions(w stand)

Width : 1039.8 mm
 Height : 757 mm
 Depth : 275 mm

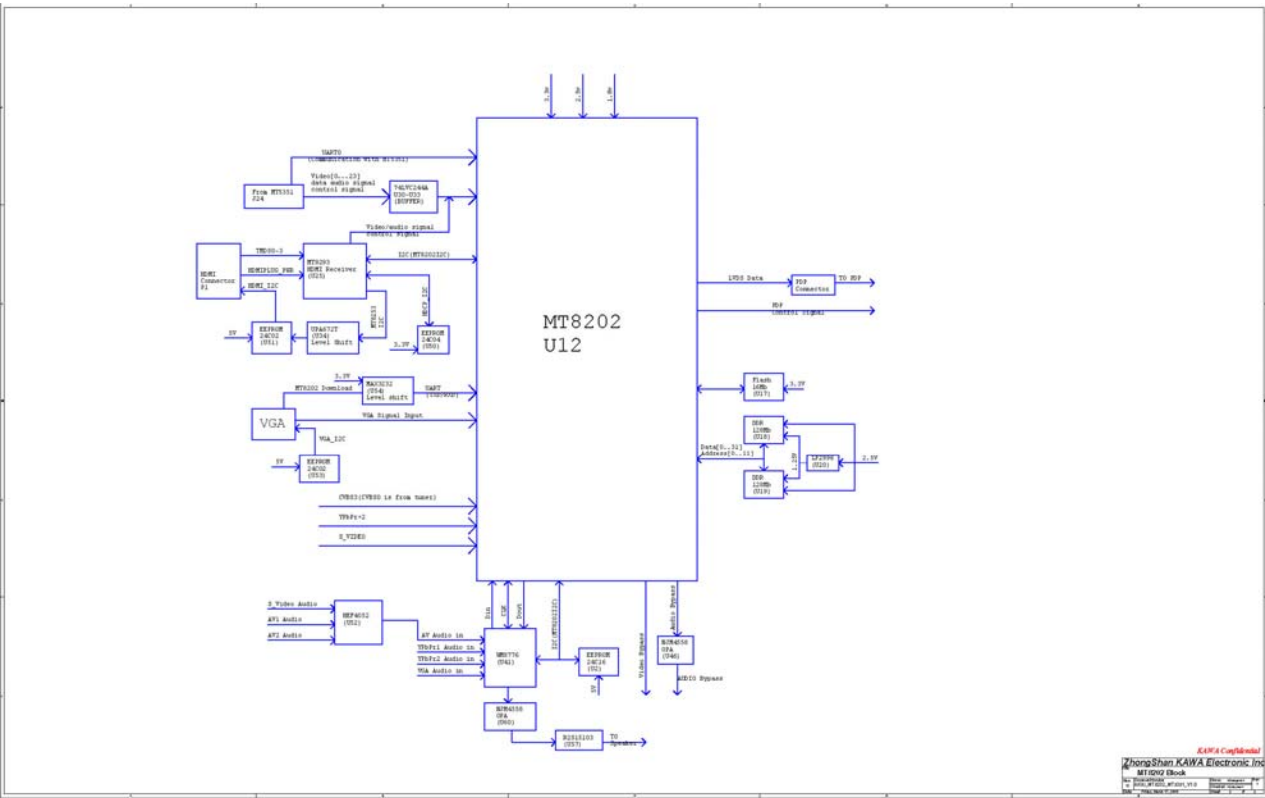

KAWA Corporation
 ZhongShan KAWA Electronic Inc.
 MT8202 Block
 Rev: 1.0
 Date: 2014-01-15

Circuit Diagram

- **Main (Video) board**
- **Keypad board**
- **Remote control receiver board**
- **External L/R Speakers board**
- **Remote control board**

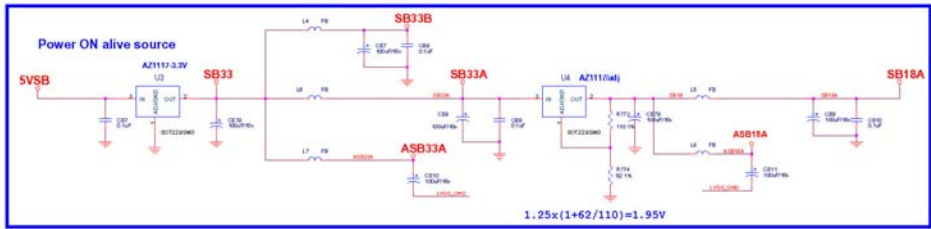

V18A_0V01 - 0 V18A_0V01 3A.12
 V18A_0V02 - 0 V18A_0V02 3A.13
 V18A_0V03 - 0 V18A_0V03 3A.14

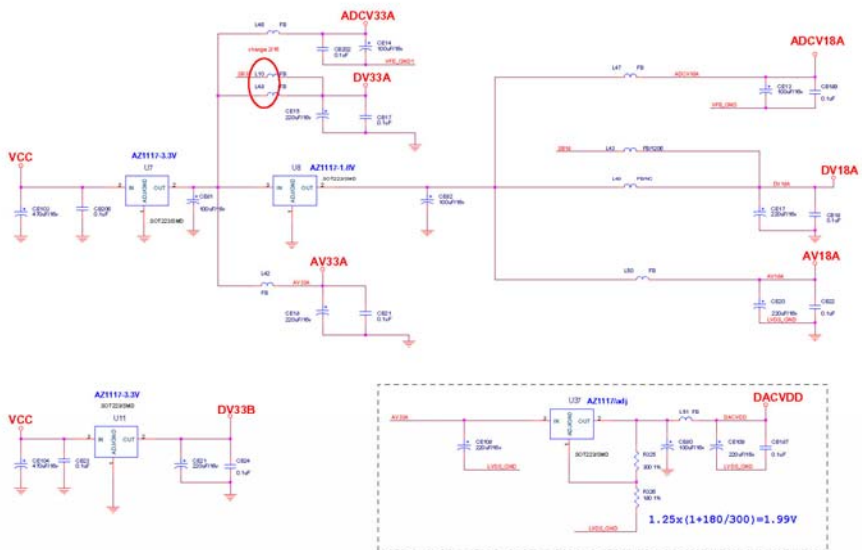

KAWA Confidential

ZhongShan KAWA Electronic Inc.

LDO

Rev	AKAL MTR02_2705_1VDS_V0.0	Drawn	Chengwei	File
C		Checked	Chengwei	
Date	17/06/2018 11:30:00	Sheet	1	of 1

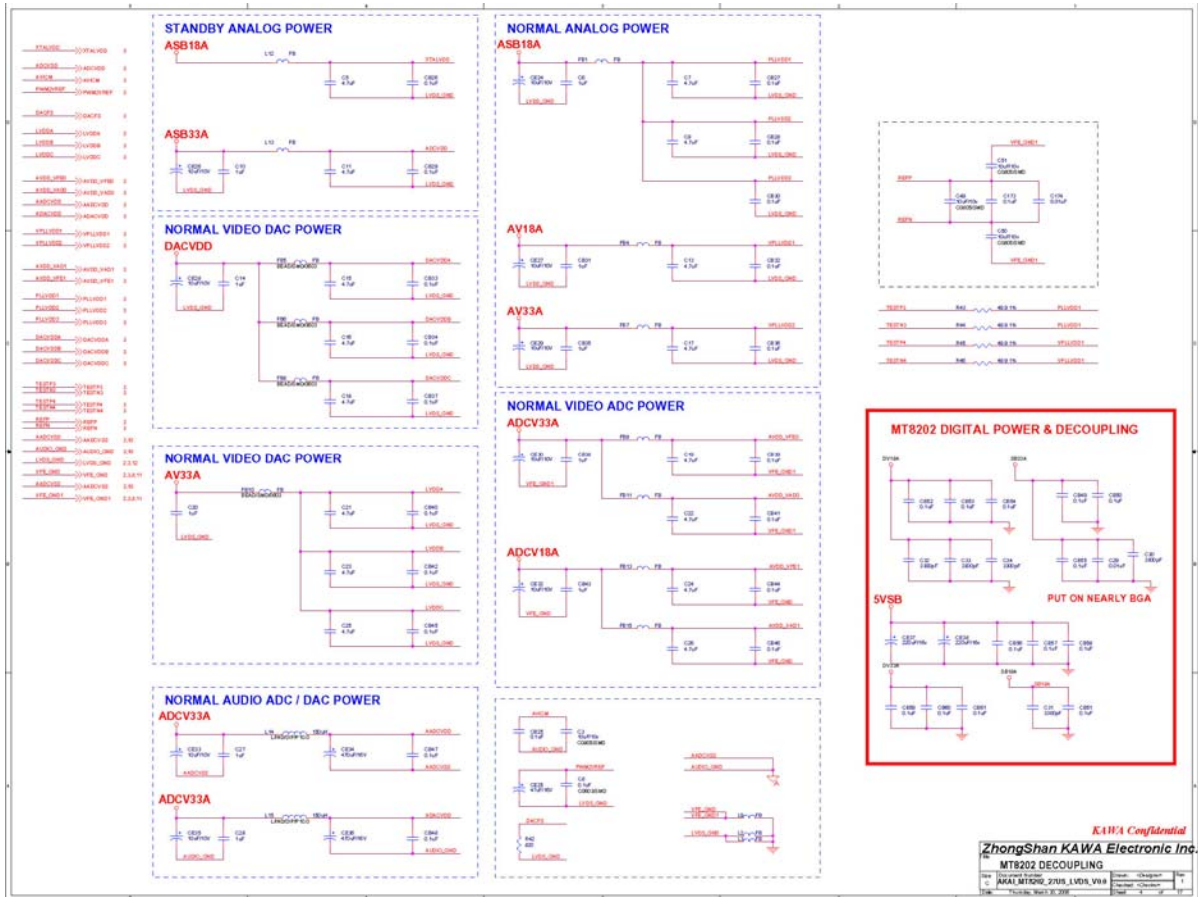

KAWA Confidential
ZhongShan KAWA Electronic Inc.
 MT8202 DECOUPLING
 Rev: 1.0
 Date: 2018.12.28

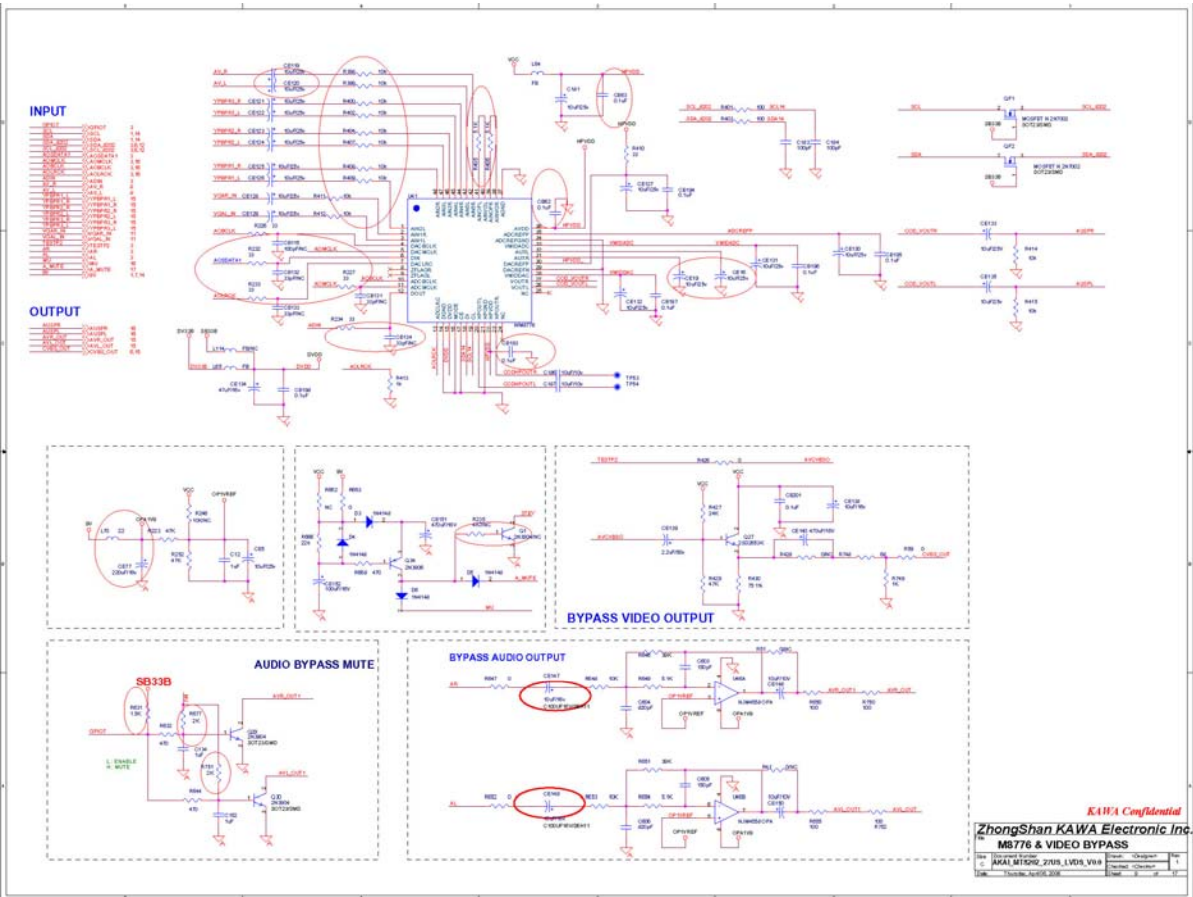

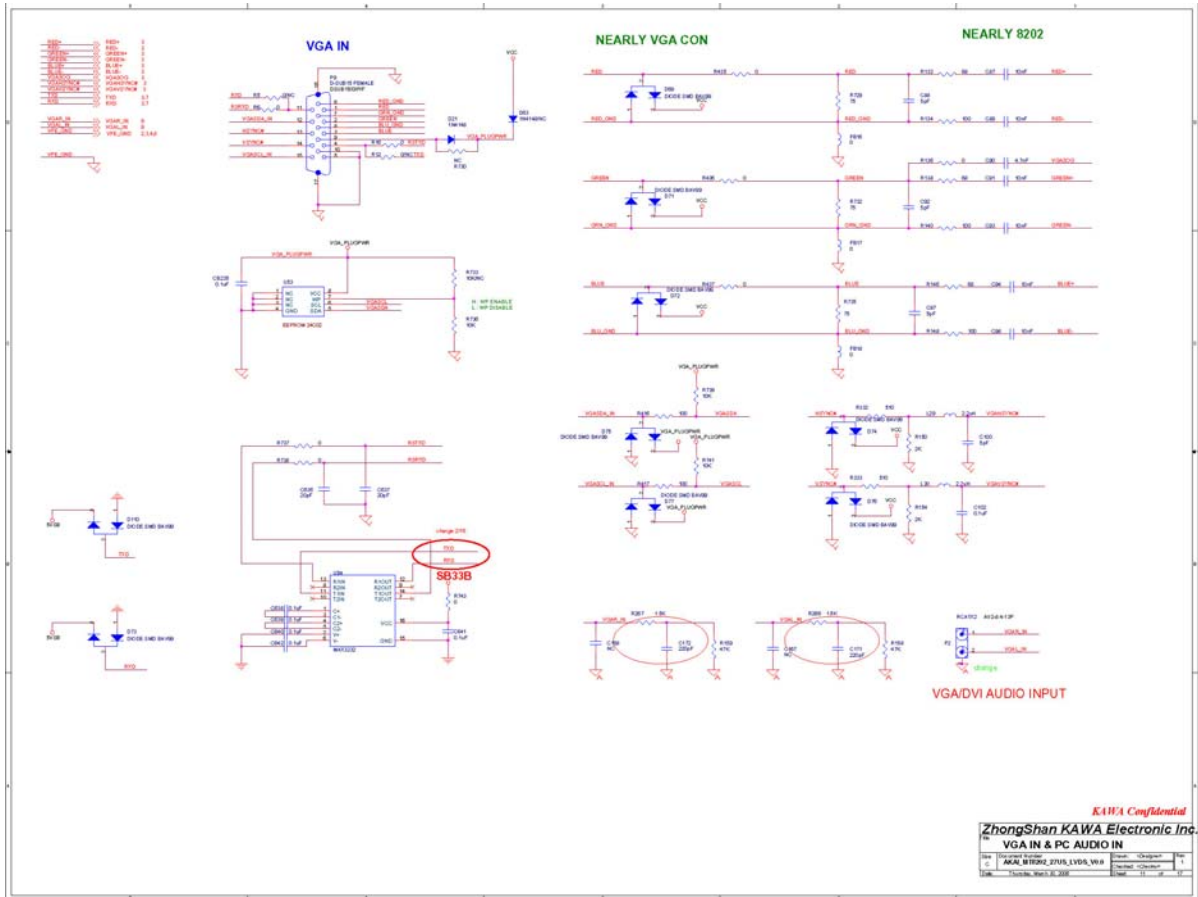

SB	» R	3,15
GPIO19	» GPIO19	3
GPIO22	» GPIO22	3
GPIO13	» GPIO13	3
GPIO14	» GPIO14	1,3
PWM0	» PWM0	3
PWM1	» PWM1	3
GPIO19_0	» GPIO19_0	3
GPIO14	» GPIO14	1,3
GPIO19	» GPIO19	1,3
V5A_K	» V5A_K	3
F_A21	» F_A21	3
DDR_V2	» DDR_V2	3
V2V	» V2V	1,12

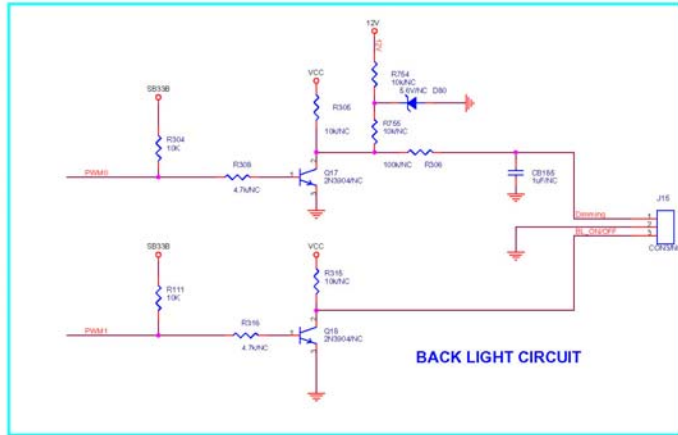
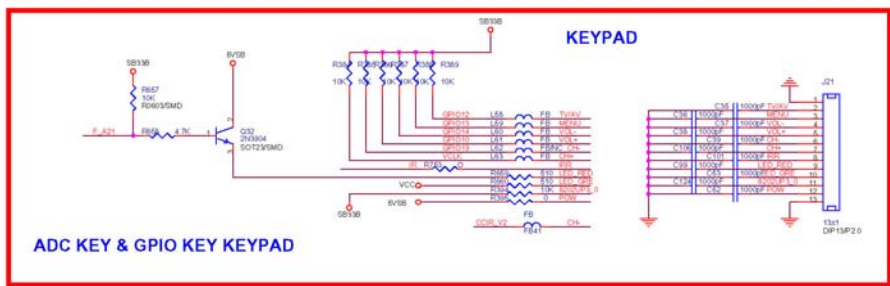

KAWA Confidential

ZhongShan KAWA Electronic Inc.

BACK LIGHT / KEYPAD

Size	Document Number	Drawn	Rev
B	AKAI_M78202_27US_LVDS_V0.0	Checked	1
Role	Toplayer_Micro01.2006	Checked	13 of 17

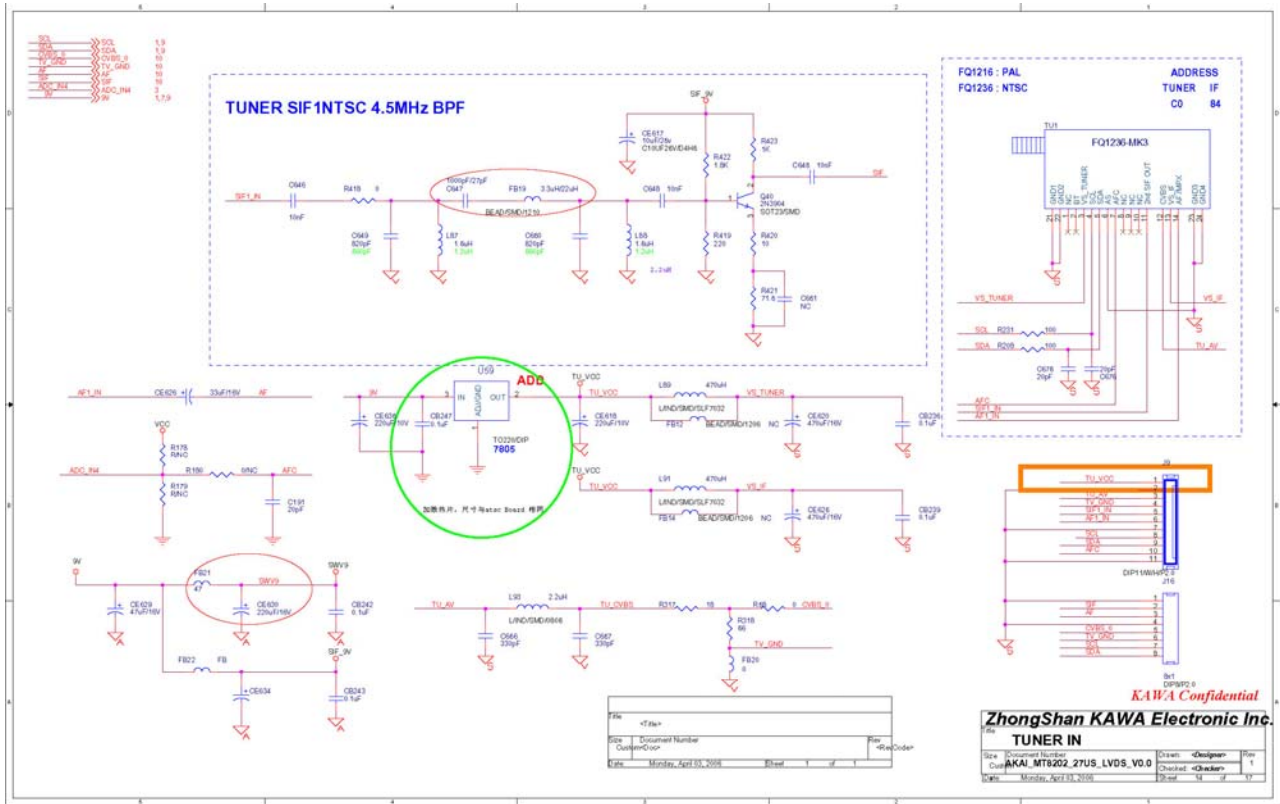

AV /YC VIDEO IN

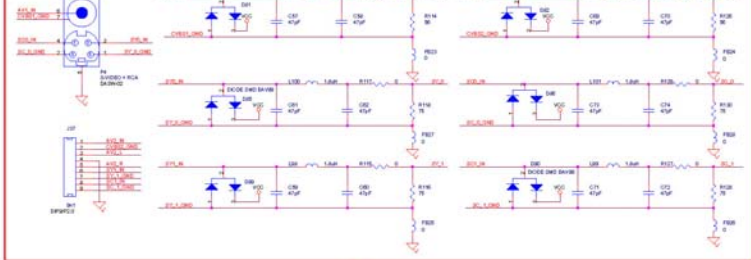

AV /YC AUDIO IN



AV /YC VIDEO IN	AV /YC VIDEO IN
AV /YC AUDIO IN	AV /YC AUDIO IN
AV VIDEO/AUDIO OUT	AV VIDEO/AUDIO OUT
YPBPR VIDEO IN	YPBPR VIDEO IN
YPBPR AUDIO IN	YPBPR AUDIO IN
YPBPR1 /2 INPUT	YPBPR1 /2 INPUT
YPBPR 3 INPUT	YPBPR 3 INPUT

AV VIDEO/AUDIO OUT

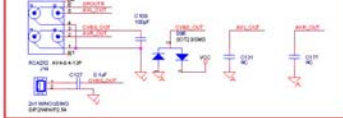

YPBPR AUDIO IN



YPBPR VIDEO IN

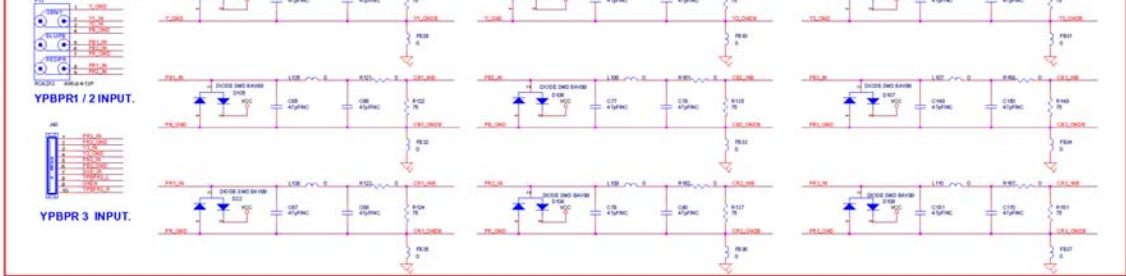

YPBPR1 /2 INPUT



YPBPR 3 INPUT



KAWA Confidential

ZhongShan KAWA Electronic Inc.
AV IN
 Date: 2013/03/20
 File: AKAL147420_2103_1.MDI_V0.0
 Page: 1 of 1
 Version: 1.0
 Date: 2013/03/20

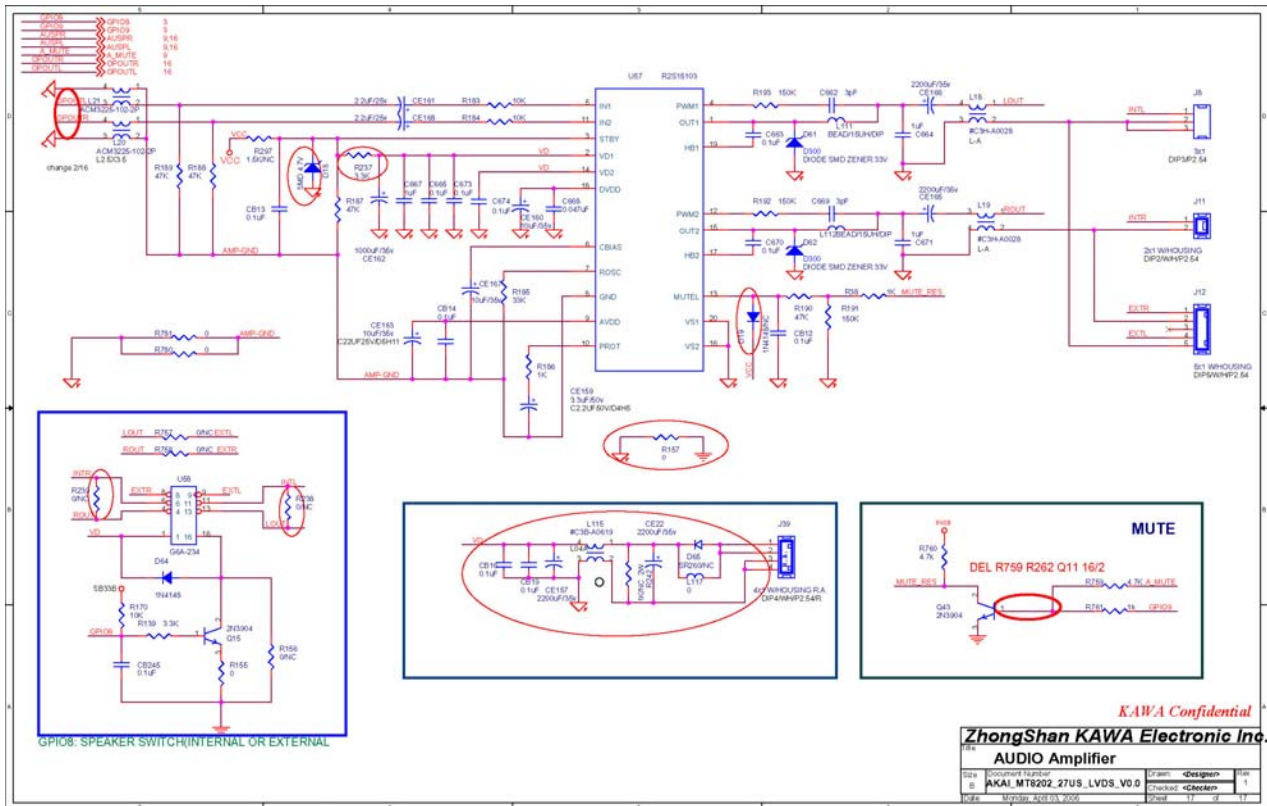

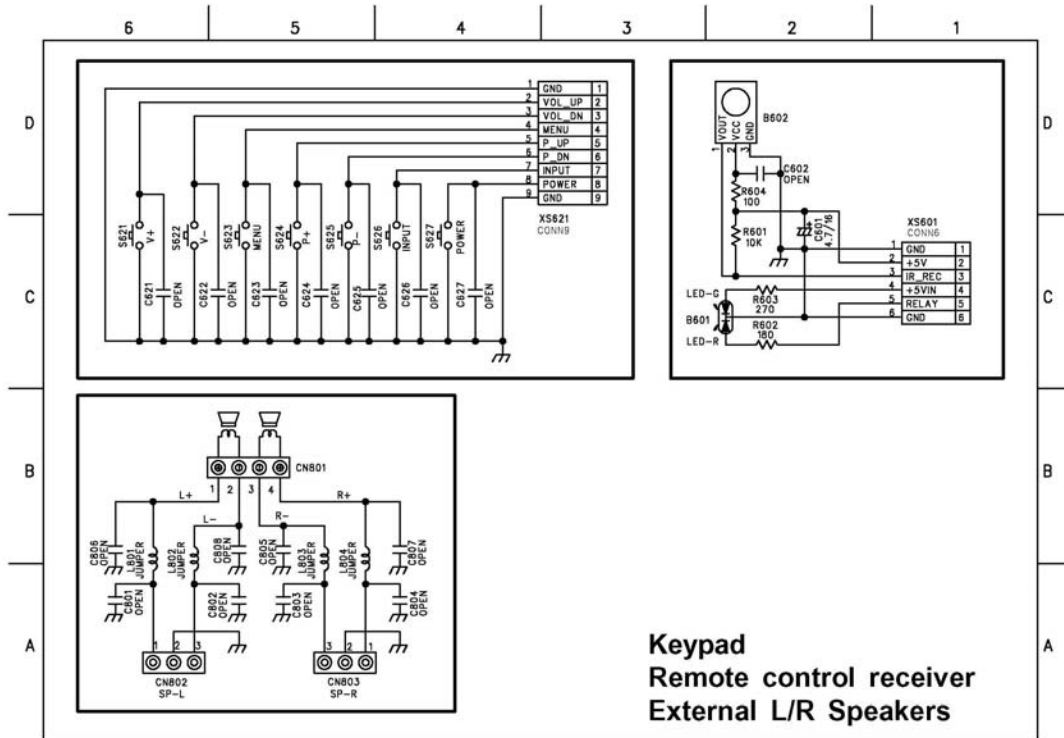

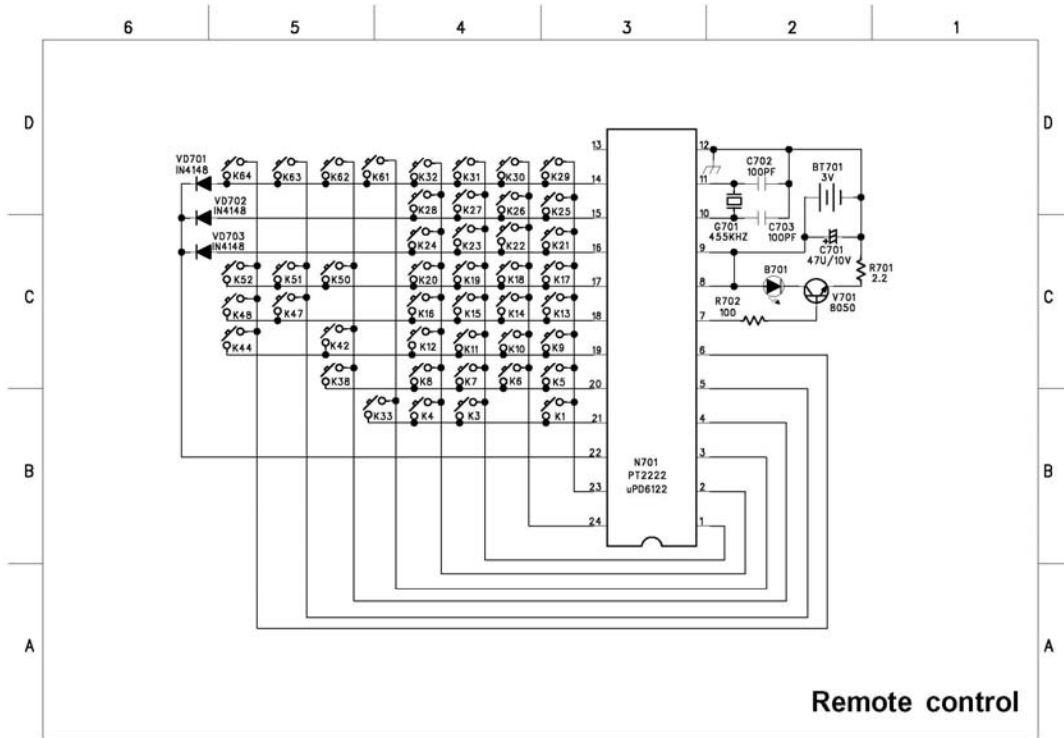

Basic operation of Plasma Display

1. After turning on power switch, PSU board sends 5Vst-by Volt to Main IC MT8202 waiting for ON signals from Key Switch or Remote Receiver.
2. When the ON signal from Key Switch or Remote Receiver is detected, MT8202 will send RLY ON and VS ON signals to PUS B/D. Then PSU B/D sends 5Vsc, 9Vsc, 24V to PCBs working. This time CONTROL Board will send signals to Panel by Z/Y SUS Board, OSD on the panel and display available signal. If the audio signals input, them will be amplified by Audio AMP and transmitted to Speakers.
3. If some abnormal signals are detected (for example: over bolts, over current, over temperature and under volts), the system will be shut down by Power off.

Parts position

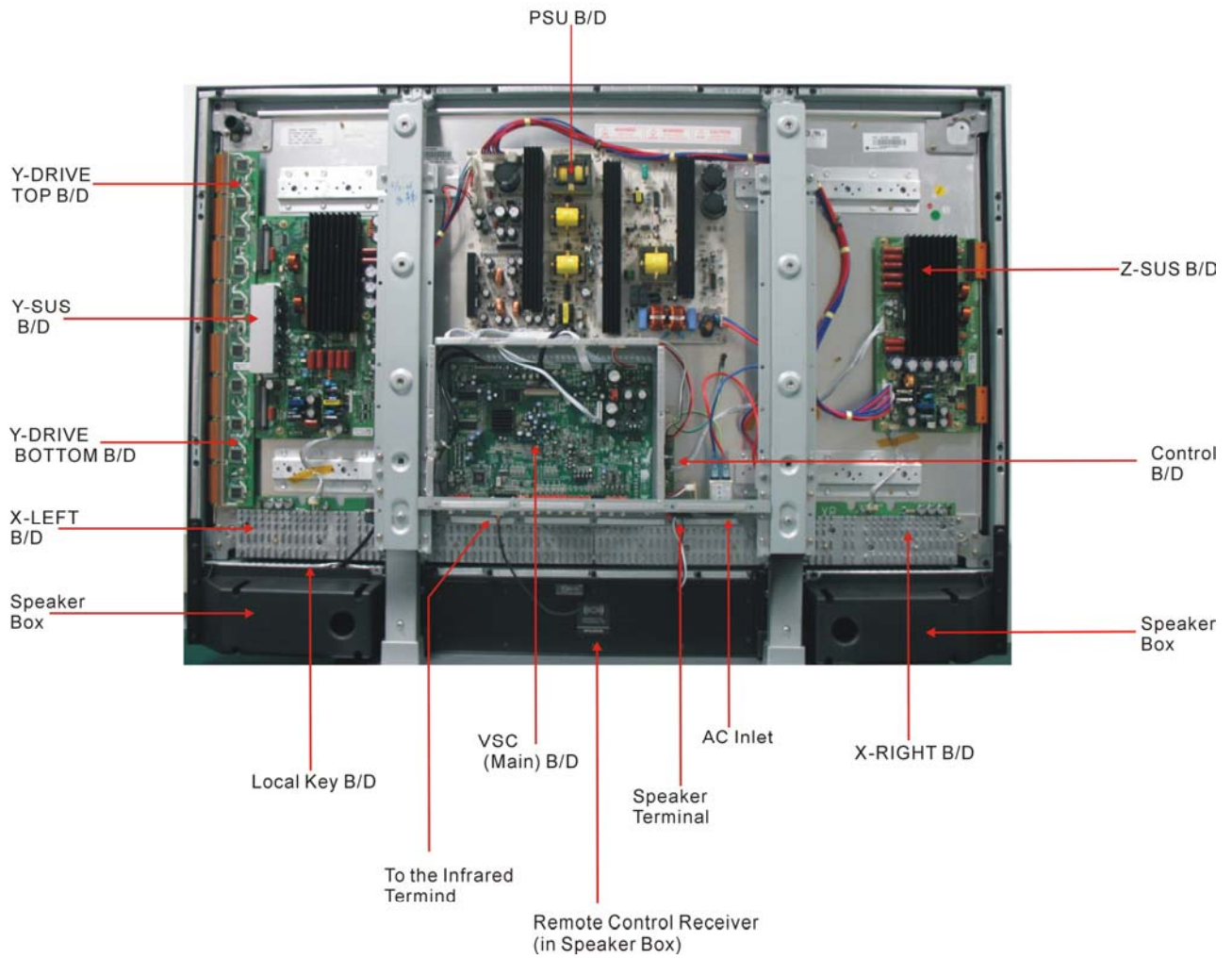

Basic Operations & Circuit Description

MODULE

There are 1 pcs panel and 8 pcs PCBs including 2 pcs Y/Z Sustainer board, 2 pcs Y Drive board, 2 pcs X (left and right) Extension board, 1 pcs Control (Signal Input) board and 1 pcs PSU board in the Module.

SET

There are 4 pcs PCBs including 1 pcs Local key board, 1 pcs Remote Control Receiver board, 1 pcs L/R Speakers and 1 pcs VSC (Main) board in the SET.

PCB function

1. PSU B/D:
 - (1). Input voltage: AC 120V, 60Hz.
 - (2). To provide power for PCBs.
2. VSC (Main) board: To converter S signals, AV signals, Y Pb/Cb Pr/Cr signals, HDMI signals and D-SUB signals to digital ones and to transmit to Control board.
3. Control board: Creates signal processing and order of many FET on/off of each DRIVE B/D with R, G, B each 10 bit input.
4. Y-Sustainer board: Generates SUSTAIN, RESET Waveform, VSC (SCAN) voltage and supplies it Y DRIVE B/D.
5. Y-Drive board:
 - (1). This is a path to supply SUSTAIN, RESET waveform which made from Y SUSTAIN B/D to Panel through SCAN DRIVER IC.
 - (2). Supply a waveform that select Horizontal electrode (Y SUSTAIN electrode) sequentially.
6. Z-Sustainer board: Make SUSTAIN PULSE and ERASE PULSE that generates SUSTAIN discharge in panel by receiving LOGIC signal from CONTROL B/D.
7. X (left and right) extension board: Receiving LOGIC signal from CONTROL B/D and make ADDRESS PULSE (generates Address discharge) by ON/OFF operation, and supplies this waveform to COF (data).

PCB failure analysis

1. CONTROL :
 - a. Abnormal noise on screen.
 - b. No picture.
2. VSC (MAIN) :
 - a. Lacking color, Bad color scale.
 - b. No voice.
 - c. No picture.
 - d. Abnormal noise on screen.
3. PSU: No picture, no power output.
4. Z - Sustainer:
 - a. No picture.
 - b. Color not enough.
 - c. Flash on screen.
5. Y – Sustainer: Darker picture with signals.
6. Y/Z – Sustainer: The component working temperature is about 55°C.

If the temperature rises abnormal, this may be a error point.

Main IC Information

- M13S128168A (ESMT)
2M x 16 Bit x 4 Banks Double Data Rate SDRAM

- MT8202
MT8202G is a highly integrated Single-Chip for LCD TV supporting video input and output format up to HDTV. It includes 3D comb filter TV decoder to retrieve the best image from popular composite signals.

- MT8293
HDMI Panel Link Cinema Receiver

- R2S15102NP
Digital Power Amplifier R2S15102NP

- WM8776
24-bit, 192kHz Stereo CODEC with 5 Channel Input Multiplexer

Panel Information

Product Specification of 42XGA PDP Module

0. Warnings and Cautions

- ✓ WARNING indicates hazards that may lead to death or injury if ignored.
- ✓ CAUTION indicates hazards that may lead to injury or damage to property if ignored.



- 1) This product uses a high voltage (450 V max.). Do not touch the circuitry of this product with your hands when power is supplied to the product or immediately after turning off the power. Be sure to confirm that the voltage is dropped to a sufficiently low level.
- 2) Do not supply a voltage higher than that specified to this product. This may damage the product and may cause a fire.
- 3) Do not use this product in locations where the humidity is extremely high, where it may be splashed with water, or where flammable materials surround it. Do not install or use the product in a location that does not satisfy the specified environmental conditions. This may damage the product and may cause a fire.
- 4) If a foreign substance (such as water, metal, or liquid) gets inside the product, immediately turn off the power. Continuing to use the products it may cause fire or electric shock.
- 5) If the product emits smoke, an abnormal smell, or makes an abnormal sound, immediately turn off the power. If noting is displayed or if the display goes out during use, immediately turn off the power. Continuing to use the product as it is may cause fire or electric shock.
- 6) Do not disconnect or connect the connector while power to the product is on. It takes some time for the voltage to drop to a sufficiently low level after the power has been turned off. Confirm that the voltage has dropped to a safe level before disconnecting or connecting the connector. Otherwise, this may cause fire, electric shock, or malfunction.
- 7) Do not pull out or insert the power cable from/to an outlet with wet hands. It may cause electric shock.
- 8) Do not damage or modify the power cable. It may cause fire or electric shock.
- 9) If the power cable is damaged, or if the connector is loose, do not use the product; otherwise, this can lead to fire or electric shock.
- 10) If the power connector or the connector of the power cable becomes dirty or dusty, wipe it with a dry cloth. Otherwise, this can lead to fire.

Product Specification of 42XGA PDP Module



General

- 1) Do not place this product in a location that is subject to heavy vibration, or on an unstable surface such as an inclined surface. The product may fall off or fall over, causing injuries.
- 2) When moving the product, be sure to turn off the power and disconnect all the cables. While moving the product, watch your step. The product may be dropped or fall, leading to injuries of electric shock.
- 3) Before disconnecting cable from the product, be sure to turn off the power. Be sure to hold the connector when disconnecting cables. Pulling a cable with excessive force may cause the core of the cable to be exposed or break the cable, and this can lead to fire or electric shock.
- 4) This product should be moved by two or more persons. If one person attempts to carry this product alone, he/she may be injured.
- 5) This product contains glass. The glass may break, causing injuries, if shock, vibration, heat, or distortion is applied to the product.
- 6) The temperature of the glass surface of the display may rise to 80°C or more depending on the conditions of use. If you touch the glass inadvertently, you may be burned.
- 7) Do not poke or strike the glass surface of the display with a hard object. The glass may break or be scratched. If the glass breaks, you may be injured.
- 8) If you glass surface of the display breaks or is scratched, do not touch the broken pieces or the scratches with bare hands. You may be injured.
- 9) Do not place an object on the glass surface of the display. The glass may break or be scratched.

Design

- 1) This product may be damaged if it is subject to excessive stresses (such as excessive voltage, current, or temperature). The absolute maximum ratings specify the limits of these stresses, and system design must ensure that none of the absolute maximum ratings are exceeded.
- 2) The materials which contain sulfur are forbidden to use, because they may damage PDP Module.
- 3) The recommended operating conditions are conditions in which the normal operation of this product is guaranteed. All the rated values of the electrical specifications are guaranteed within these conditions. Always use the product within the range of the recommended operating conditions. Otherwise, the reliability of the product may be degraded. Use of the product with a combination of parameters, conditions, or logic not specified in the specifications of this product is not guaranteed. If intending to use the product in such a way, be sure to consult LGE in advance.
- 4) This product emits near infrared rays (800 to 1000nm) that may cause the remote controllers of other electric products to malfunction. To avoid this, use an infrared absorption filter and thoroughly evaluate the system and environment.

Product Specification of 42XGA PDP Module

□ Design (continued)

- 5) This product uses high-voltage switching and a high-speed clock. A system using this product should be designed so that it does not affect the other systems, and should be thoroughly evaluated.
- 6) This product has a glass display surface. Design your system so that excessive shock and load are not applied to the glass. Exercise care that the vent at the corner of the glass panel is not damaged. If the glass panel or vent is damaged, the product is inoperable.
- 7) There are some exposed components on the rear panel of this product. Touching these components may cause an electric shock.
- 8) This product uses a high voltage. Design your system so that any residual voltage in this product is dissipated quickly when power is turned off, observing the specifications.
- 9) This product uses heat-emitting components. Take the heat emitted by these components into consideration when designing your system. If the product is used outside the specified temperature range, it may malfunction.
- 10) This product uses a high voltage and, because of its compact design, components are densely mounted on the circuit board. If dust collects on these components, it can cause short-circuiting between the pins of the components and moisture can cause the insulation between the components to break down, causing the product to malfunction.
- 11) Regulations and standards on safety and electromagnetic interference differ depending on the country. Design your system in compliance with the regulations and standards of the country for which your system is intended.
- 12) To obtain approval under certain safety standards (such as UL and EN), a filter that passes a shock test must be fitted over the glass surface of the finished product. In addition, it must be confirmed that the level of UV emissions is within the range specified by such standards.
- 13) If this product is used as a display board to display a static image, "image sticking" occurs. This means that the luminance of areas of the display that remain lit for a long time drops compared with the luminance of areas that are lit for a shorter time, causing uneven luminance across the display. The degree to which this occurs is in proportion to the luminance at which the display is used. To prevent this phenomenon, therefore, avoid static images as much as possible and design your system so that it is used at a low luminance, by reducing signal level difference between bright area and less bright area through signal processing.
- 14) Within the warranty period, general faults that occur due to defects in components such as ICs will be rectified by LGE without charge. However, IMAGE STICKING is not included in the warranty. Repairs due to the other faults may be charged for depending on responsibility for the faults.
- 15) In case of AC PDP driving mechanism, Because the brightness of output is not always proportional to input signals. Therefore the non-linearity of gray can occasionally be observed in certain gray levels as well as Contour and Error Diffusion Noise can be appeared when a dark picture is on the screen especially. These are phenomena that can be observed on the PDP driving mechanism. With simple adjustment to picture brightness control, these can be reduced considerably.
- 16) Because of the need to control the power consumption on the PDP driving mechanism, the APL(Average Picture Level) mode was equipped. Thus, as the picture on the screen changes, there can be slightly switched in brightness. This also is a phenomenon that can be observed on the PDP driving mechanism.
- 17) This product is designed to LGE's "Standard" quality grade. If you wish to use the product for applications outside the scope of the "Standard" quality grade, be sure to consult LGE in advance to assess the technological feasibility before starting to design your system.

Product Specification of 42XGA PDP Module

USE

- 1) Because this product uses a high voltage, connecting or disconnecting the connectors while power is supplied to the product may cause malfunctioning. Never connect or disconnect the connectors while the power is on. Immediately after power has been turned off, a residual voltage remains in the product. Be sure to confirm that the voltage has dropped to a sufficiently low level.
- 2) Watching the display for a long time can tire the eyes. Take a break at appropriate intervals.
- 3) PDP's brightness and contrast ratio is lower than that of the CRT. The picture is dimmer with surrounding light and better for viewing in dark condition.
- 4) Do not cover or wrap the product with a cloth or other covering while power is supplied to the product.
- 5) Before turning on power to the product, check the wiring of the product and confirm that the supply voltage is within the rated voltage range. If the wiring is wrong or if a voltage outside the rated range is applied, the product may malfunction or be damaged.
- 6) Do not store this product in a location where temperature and humidity are high. This may cause the product to malfunction. Because this product uses a discharge phenomenon, it may take time to light (operation may be delayed) when the product is used after it has been stored for a long time. In this case, it is recommended to light all cells for about 2hours (aging).
- 7) If the glass surface of the display becomes dirty, wipe it with a soft cloth moistened with a neutral detergent. Do not use acidic or alkaline liquids, or organic solvents.
- 8) Do not tilt or turn upside down while the module package is carried, the product may be damaged.
- 9) This product is made from various materials such as glass, metal, and plastic. When discarding it, be sure to contact a professional waste disposal operator.

Repair and Maintenance

Because this product combines the display panel and driver circuits in a single module, it cannot be repaired or maintained at user's office or plant. Arrangements for maintenance and repair will be determined later

Others

- 1) If your system requires the user to observe any particular precautions, in addition to the above warnings and cautions, include such caution and warning statements in the manual for your system.
- 2) If you have any questions concerning design, such as on housing, storage, or operating environment, consult LGE in advance.

1. GENERAL DESCRIPTION

□ DESCRIPTION

The PDP42X3##### 42-inch 16:9 color plasma display module with resolution of 1024(H) × 768(V) pixels. This is the display device which offers vivid colors with adopting AC plasma technology by LG Electronics Inc.

□ FEATURES

High peak brightness (1,200cd/m² Typical) and high contrast ratio (10,000:1 Typical) enables user to create high performance PDP SETs.

□ APPLICATIONS

- ✓ General television systems
- ✓ Public information display
- ✓ Video conference systems
- ✓ Education and training systems



Product Specification of 42XGA PDP Module

□ ELECTRICAL INTERFACE OF PLASMA DISPLAY

The PDP42X3##### requires 8bits or 10bits of digital video signals for each RGB color.
In addition to the video signals, six different DC voltages are required to operate the display.

□ GENERAL SPECIFICATIONS

- ✓ Model Name : PDP42X3##### (42X3 Model)
- ✓ Number of Pixels : 1024(H) × 768(V) (1pixel=3 RGB cells)
- ✓ Pixel Pitch : 900 μ m (H) × 676 μ m (V)
- ✓ Cell Pitch : 300 μ m (H) × 676 μ m (V) (Green Cell basis)
- ✓ Display Area : 921.6(H) × 519.2(V) ±0.5mm
- ✓ Outline Dimension : 1005(H) × 597(V) × 61.2(D)±1mm
- ✓ Pixel Type : RGB Closed type
- ✓ Number of Gradations : (R)1024 × (G)1024 × (B)1024
- ✓ Weight : 14.2 Kg ± 0.5 Kg (Net 1EA)
90.5 Kg ± 5 Kg (5EA/1BOX)
- ✓ Aspect Ratio : 16:9
- ✓ Peak Brightness : Typical 1200cd/m² (1/100 White Window)
- ✓ Contrast Ratio : Typical 140:1 (In a bright room with 100Lux at center)
: Typical 10000:1 (In a dark room 1/100 White Window pattern at center)
- ✓ Power Consumption : Typical 280 W (Full White), Max.330W (Full White)
- ✓ Expected Life-time : more than 60,000 Hours of continuous operation
 - ☞ Life-time is defined as the time when the brightness level becomes half of its initial value.

✓ Display Dot Diagram

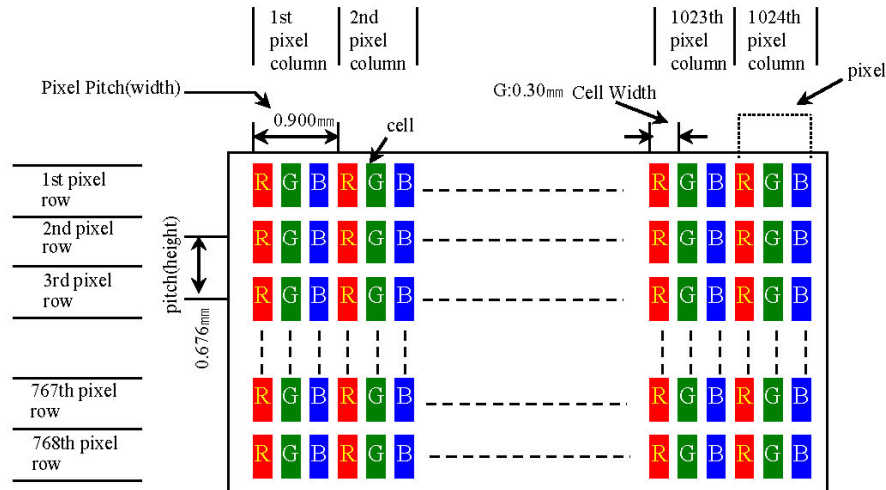

Product Specification of 42XGA PDP Module

□ BLOCK DIAGRAM

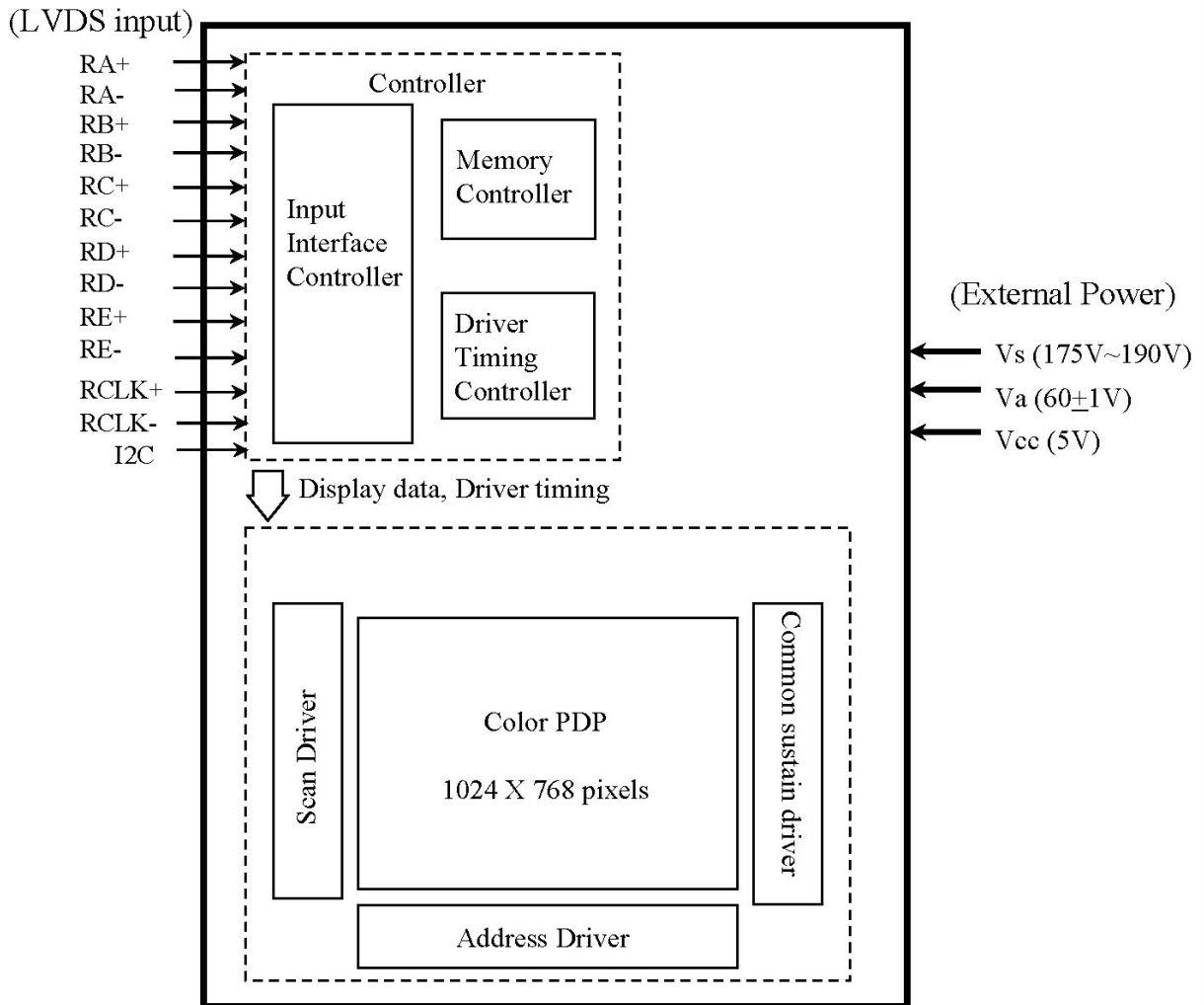

☞ Applied Voltage level is specified at the time when Full-White pattern is displayed on the panel.

Product Specification of 42XGA PDP Module

2. ELECTRICAL SPECIFICATIONS

□ Absolute Power Specifications

Item	Symbol	Condition	Min.	Max.	Unit	Remarks
Logic Voltage	Vcc	25°C	4.5	6	V	
Address Voltage	Va	25°C	-	70	V	
Sustain Voltage	Vs	25°C	-	220	V	

□ Input Power Specifications

➤ Logic Power Supply(Vcc)

Item	Condition	Min.	Typ.	Max.	Unit
Input Range	-	4.75	5.0	5.25	V
Voltage Stability	-	-	-	± 3.0	%
Average Current	-	0.5	2.0	4.0	A _{mean}
Peak Current	-	-	-	8.5	A
Ripple	-	-	-	30	mV _{p-p}
Noise	-	-	-	300	mV _{p-p}

➤ Address Power Supply(Va)

Item	Condition & Remarks	Min.	Typ.	Max.	Unit
Adjustable Range	Dependent on the characteristics of each PDP	59	60	61	V
Voltage Stability	-	-	-	± 1.5	%
Average Current	Variable with the image	0.01	-	2.0	A _{mean}
Ripple & Noise	-	-	-	300	mV _{p-p}

➤ Sustain Power Supply(Vs)

Item	Condition	Min.	Typ.	Max.	Unit
Adjustable Range	Dependent on the characteristics of each PDP	175	-	190	V
Voltage Stability	-	-	-	± 1.0	%
Peak Current	-	-	-	20	A
Average Current	Dependent on the characteristics of each PDP	0.1	-	1.5	A _{mean}
Voltage Regulation	At the peak current	-	-	3	V
Ripple & Noise	-	-	-	500	mV _{p-p}

☞ Voltage should be set to a specified value which is indicated on the label attached to the module.

Product Specification of 42XGA PDP Module

□ LVDS Signal

➤ Video Input Connector (P31) → LG Cable, GT121-31P-TD

Pin No.	Symbol	Pin No.	Symbol	Pin No.	Symbol
1	GND	11	RD-	21	nc
2	RA-	12	RD+	22	nc
3	RA+	13	GND	23	nc
4	RB-	14	GND	24	RE-
5	RB+	15	nc	25	RE+
6	GND	16	nc	26	GND
7	RC-	17	nc	27	DISPEN
8	RC+	18	nc	28	I ² C SDA
9	RCLK-	19	GND	29	I ² C SCL
10	RCLK+	20	nc	30	nc
				31	GND

} 3.3V level

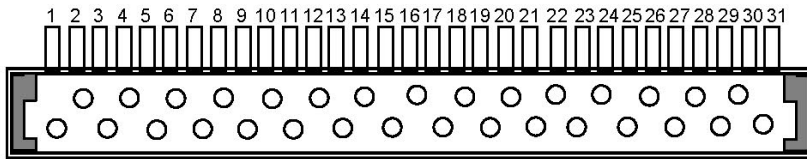

LG Cable, GT121-31P-TD pin number (Top view)

➤ Definitions and Functions of LVDS Signal

Symbol	Definition and Function	Related Output Signal
RA +	Channel-A Pos. Receiver Input	R4, R5, R6, R7, R8, R9, G4
RA -	Channel-A Neg. Receiver Input	
RB +	Channel-B Pos. Receiver Input	G5, G6, G7, G8, G9, B4, B5
RB -	Channel-B Neg. Receiver Input	
RC +	Channel-C Pos. Receiver Input	B6, B7, B8, B9, Hsync, Vsync, BLANK
RC -	Channel-C Neg. Receiver Input	
RD +	Channel-D Pos. Receiver Input	R2, R3, G2, G3, B2, B3, nc
RD -	Channel-D Neg. Receiver Input	
RE +	Channel-E Pos. Receiver Input	R0, R1, G0, G1, B0, B1, nc
RE -	Channel-E Neg. Receiver Input	
RCLK +	Clock Pos. Receiver Input	PIX_CLK
RCLK -	Clock Neg. Receiver Input	

Product Specification of 42XGA PDP Module

4. MECHANICAL & ENVIRONMENTAL SPECIFICATIONS

Mechanical Characteristic Specifications

Item		Spec.	Unit	Remark
Outline Dimensions		1,005(H) × 597(V) × 60.7(D) ± 1	mm	See "Outline Drawing"
Display Area		921.6 (H) x 519.2 (V) ± 0.5	mm	
Weight	Net	14.3 ± 0.5 (1EA)	kg	
	Gross	91 ± 5 (5EA/1BOX)	kg	
Audible Noise		≤35 dB	dB	1 M (white , Front side)

Vibration and Drop Specifications

Item	Condition	Remark
Vibration	▶ 1.25G, 5 to 55Hz (Sweep time : 2Min.), Y Direction, 60 Minutes	▶ Non operation ▶ Sea Packed state
Drop	▶ Bottom : Free falling : 30cm	
	▶ The rest (Front, Backside) : Inclined Falling : 20- 30 cm	

Recommended Environmental Conditions

Item		Condition	Remark
Ambient Temperature	Operation	0°C to 40°C	Panel surface temperature must be kept less than 63°C for normal operation.(module base)
	Storage	-20°C to 60°C	.
Humidity	Operation	20 to 80% RH	No condensation
	Storage	10 to 90% RH	
Air Pressure	Operation	800 to 1,100 hPa	0~2000m above the sea level
	Storage	700 to 1,100 hPa	0~3000m above the sea level

5. IMAGE STICKING CHARACTERISTICS

Image Sticking

The fluorescent substance used in the plasma module loses its brightness with the lapse of lighting time. This deterioration in brightness appears to be a difference in brightness in relation to the surroundings, and comes to be recognized as image sticking.

In other words, the image sticking is defined as follows: when the same pattern (of the fixed display) is displayed for a long time, a difference in brightness is caused around the lighting area and non-lighting area due to deterioration in the fluorescent substance.

When the present pattern is changed over to another one, the boundary comes to be seen between the lighting area and non-lighting area due to difference in brightness in the pattern shown shortly before changeover. If this conditions is accumulated, the boundary or image sticking comes to be seen with the naked eyes.

Secular change in brightness

The life of brightness, defined as the reduction to half the initial level, is more than 25 thousand hours on average.

Conditions: All white (100% white) input at an ambient temperature of 25°C.

However, this lifetime is not a guarantee value for life and brightness. It should be recognized simply as the data for reference.

Warranty

Image sticking and faults in brightness and picture elements are excluded from the warranty objects.

Cause of deterioration in brightness

A major possible cause of deterioration in brightness is damage in the fluorescent substance due to impact caused by ions generated at the time of plasma discharges.

Practical value for Image sticking

The relationship between integrated lighting time and brightness in this plasma module is described in the attached material. In particular, the deterioration in brightness tends to be accelerated up to 100 hours in the initial period. In the initial period, the fixed display of patterns particularly tends to cause image sticking. The practical value for image sticking is difficult in concrete numerals. As described below, you are advised to take proper measures to make the occurrence of image sticking as slow as possible.

Product Specification of 42XGA PDP Module

□ Proposed measures taken to relieve image sticking

So long as there is the reduction of brightness in the fluorescent substance, it is impossible to avoid the occurrence of image sticking. Therefore, to relieve image sticking, we offer you a method of entering an image input that may ensure reluctance to the generation of the difference in brightness reduction among the displayed dots.

The images from TV broadcasting involve a high rate of motion picture displays. Therefore, there is less chance of being a cause of difference in brightness reduction among the cells. Even when the fixed patterns are displayed, they generally last for a few minutes. Since the same pattern is less liable to be displayed, there is almost no influence toward image sticking.

If the fixed patterns tend to be displayed for a long time, however, there occurs a substantial imbalance between the lighting and non-lighting areas, thus causing a difference in brightness as a result. In this document, we offer you some proposals of installation, paying attentions to the two points: the reduction of difference in brightness achieved by integrated lighting time leveling and the method of edge smearing to make image sticking hard to be discerned.

The result from these proposals can, however, greatly depend on the contents of images and the operating environment. Therefore, we consider that it is essential to take the suitable measures in consideration of the customer's operating environment.

Example of Proposal 1: The display position is moved while the fixed display pattern is changed over, or it is scrolled during the display.

Example of Proposal 2: If possible, a pattern of complementary color is incorporated (for integrated time leveling).

Example of Proposal 3: The fixed pattern and the motion picture display are reciprocally exchanged, in order to minimize display period of the fixed pattern.

Example of Proposal 4: During operation, the brightness of screen is suppressed as low as possible. For the display patterns, characters are indicated not on the black ground (non-picture area) but on the colored ground (mixture of R, G, B recommended).

6. OUTLINE DRAWING

□ Front View

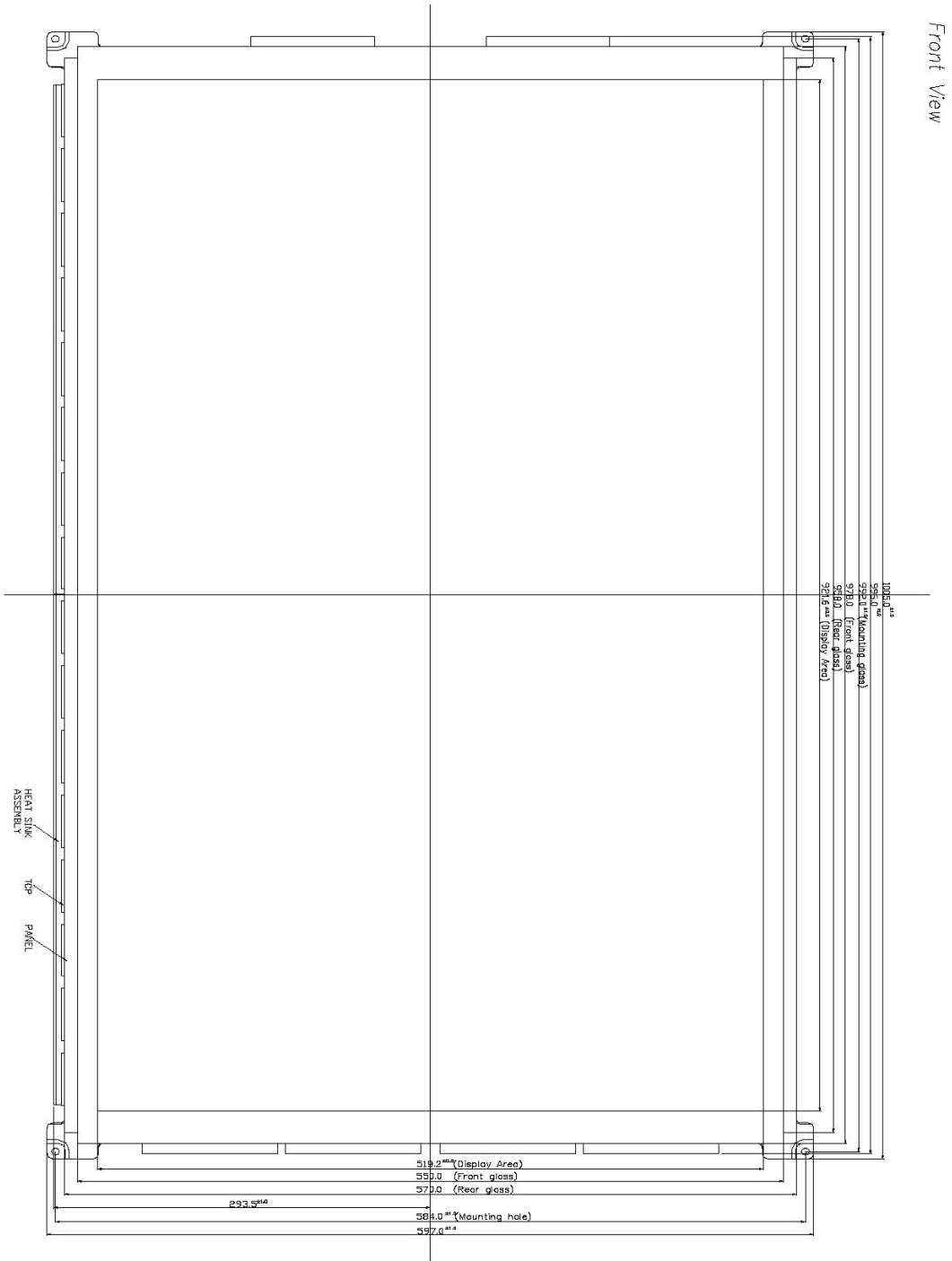

Product Specification of 42XGA PDP Module

❑ Rear View

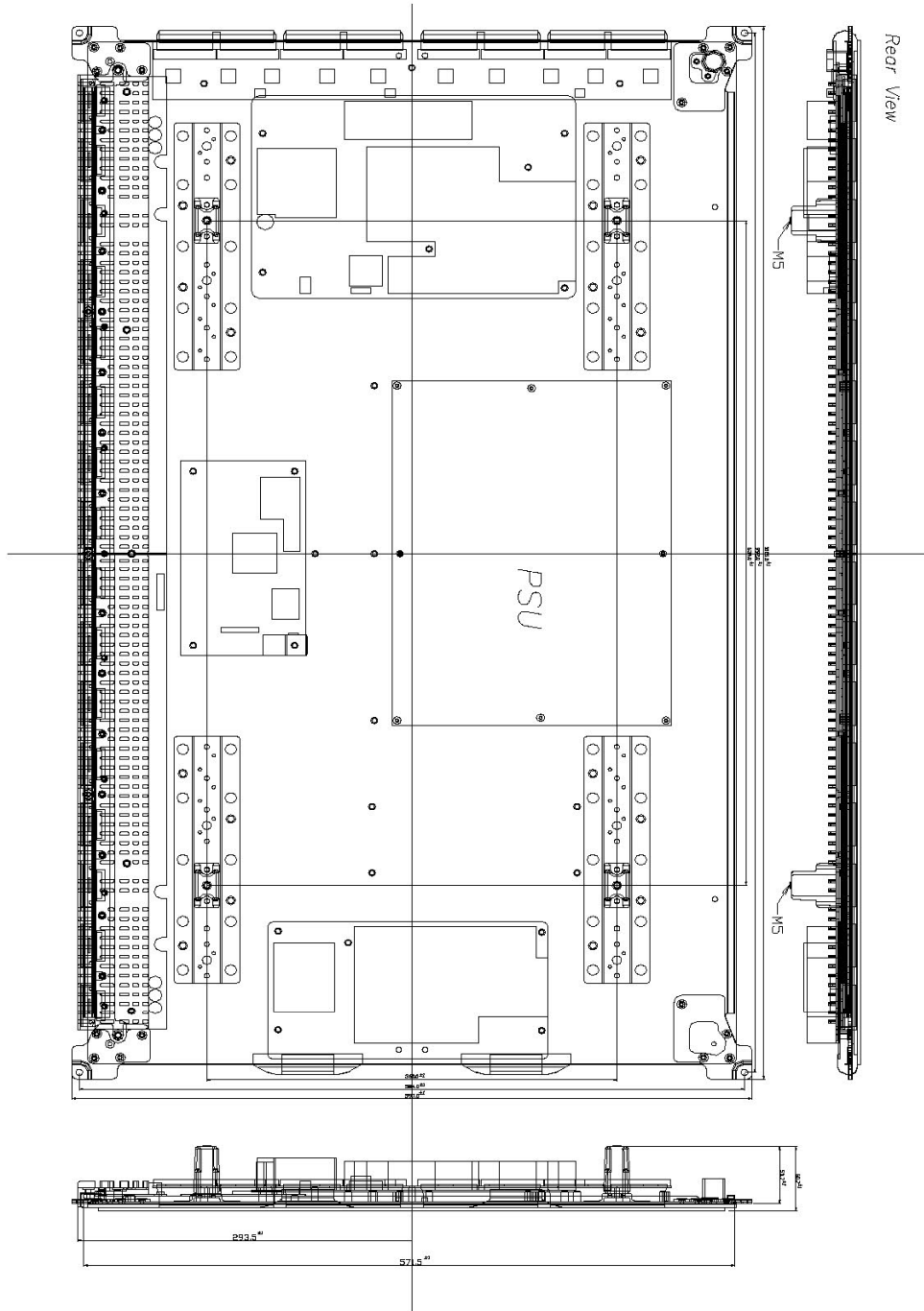

8. LG OEM panel parts list

*****Same panel as the panel in an LG 42PC3D*****

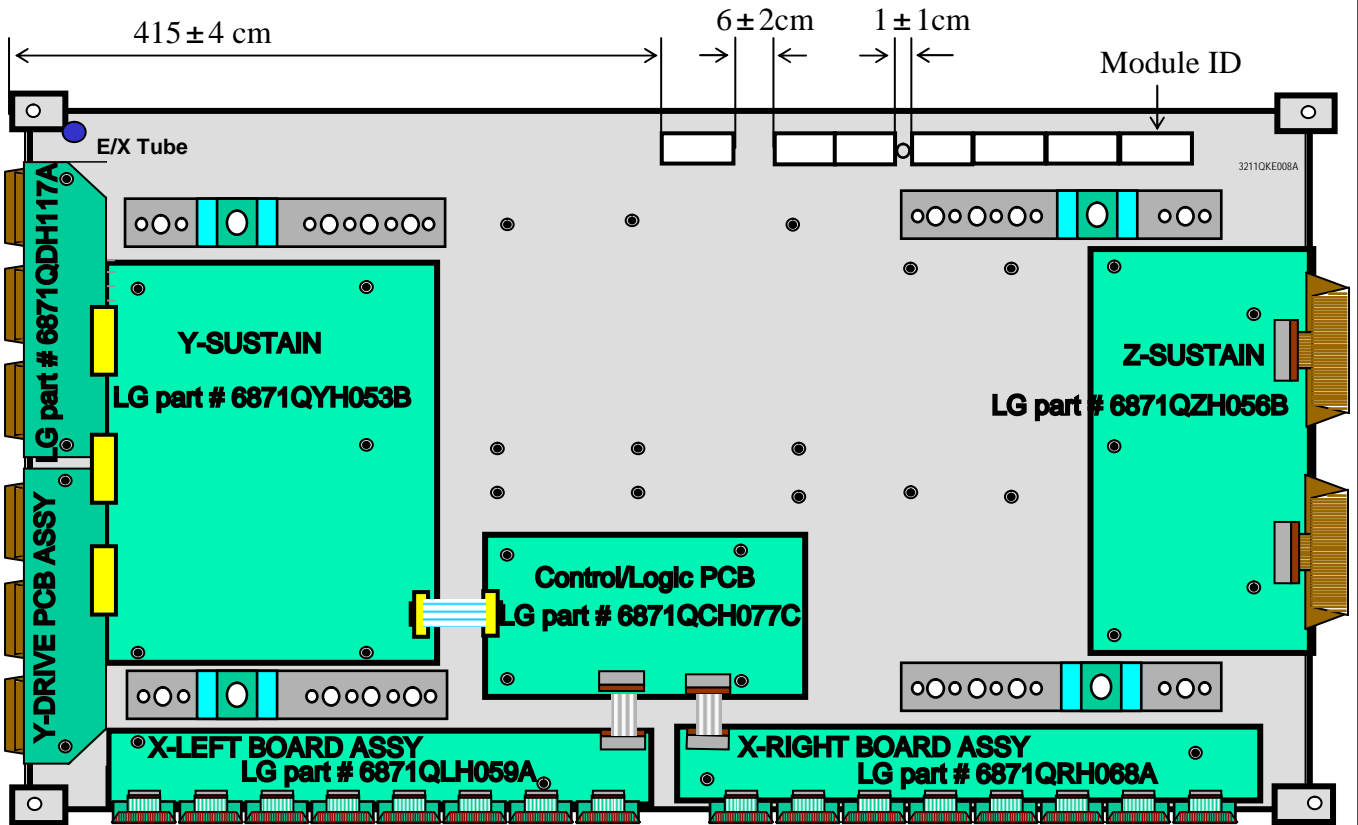

These parts are regular LG panel parts and can be ordered from any distributor of LG parts. Please make sure to fax or email a copy of the invoice the service dept so an adjustment can be made to the claim for in-warranty claims.

7. CONNECTORS and CONNECTIONS

□ Power Input Connector

Connector P2002 Pin Assignment(Y SUS Board)

Pin No.	Symbol	Pin No.	Symbol
1	+5V	7	NC
2	GND	8	Vs
3	Va	9	Vs
4-6	GND		

1-1123723-9 Pin numbers
(view from the pin connection side)

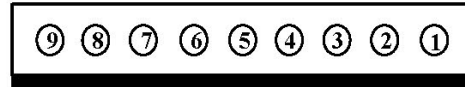

Module side connector : 1-1123723-9 (Header)
 Mating Connector : 1-1123722-9 (Housing)
 Connector Supplier : AMP

Connector P3001 Pin Assignment (Z SUS Board)

Pin No.	Symbol	Pin No.	Symbol
1	Vs	5	GND
2	Vs	6	Va
3	N.C	7	GND
4	GND	8	+5V

1-1123723-8 Pin numbers
(View from the pin connection side)



Module side connector : 1-1123723-8 (Header)
 Mating Connector : 1-1123722-8 (Housing)
 Connector Supplier : AMP

Product Specification of 42XGA PDP Module

□ Identification Label : LABEL

□ LABEL ① : Identification Label



- ① Model Name
- ② Bar Code (Code 128, Contains The Manufacture No.)
- ③ Manufacture No.
- ④ The Trade Name of LG Electronics
- ⑤ Manufactured Date (Year & Month)
- ⑥ The Place of Origin
- ⑦ Model Suffix

□ LABEL ② : Warning Label (High Voltage, Hot Surface, Wound)

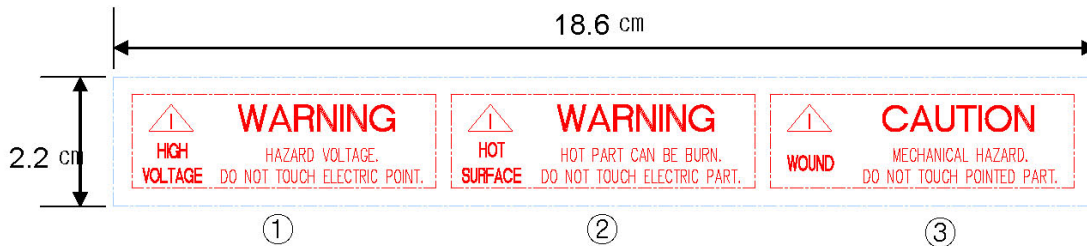

- ① Warning (High Voltage, Hazard Voltage)
- ② Warning (Hot Surface, Hot part can be burn)
- ③ Caution (Wound, Mechanical Hazard)

Product Specification of 42XGA PDP Module

9. PACKING

□ Box packing (5 modules per each Box)

1. Prepare to Module & Packing sheet (Grid)

-Put the Module on the printed surface as four holes at the sheet locate to down of the module like the picture below.

-It has to use some supporter of 10cm height in the bottom of the module.



2. Wrapping Packing sheet

- Fold the packing sheet, align 4 holes of the sheet with support sides of the module and then tapping.

-Do not fold the right/left side of the sheet.



3. Connect Cover Plate

-Connect M4 screw(6 positions)

-Screw torque: 17~20kgf.cm

-The shape of Cover Plate is same (Top/Bottom, Right/Left)

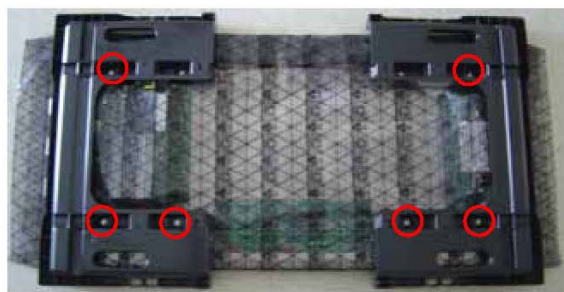

4. Prepare bottom Box for Packing

-The arrow direction at the bottom packing Should be front side.

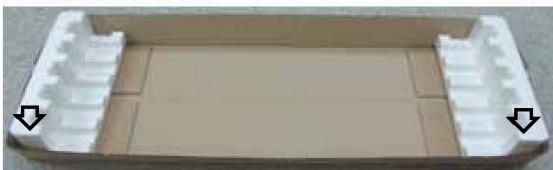

5. Insert wrapped modules with top packings

-Insert wrapped modules arrow direction of the bottom packing in the bottom box.

-Top packings should be inserted front side like the picture below.



6. Put Box, Tapping and Banding

-Put Box on Module(the direction of Box should be same direction as front side of Module.

-Box Tapping should be down to 10cm at right/left side like picture as shown below.

- Box banding by using the location of Banding guide.

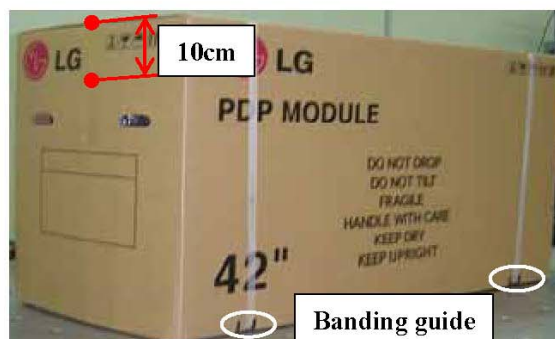

Product Specification of 42X3 SANKEN PSU

1. Input Specification

1.1 Input condition

Standard Voltage Range	AC 100V ~ 240V
Available Voltage Range	AC 90V ~ 265V
Frequency Range	50Hz ~ 60Hz (± 5Hz)

1.2 Others

Item	Specification	Test Condition
Efficiency	83% Min	<ul style="list-style-type: none"> • AC 220V • At Full Load
Inrush Current	40A peak Max	

2. Safety & EMS Specification

Item	Specification	Test Condition
Dip Up Test	<ul style="list-style-type: none"> •Must Satisfy Level A* Must Satisfy Level B* 	<ul style="list-style-type: none"> •100%±0.5T, 100%1.0T, 100%2.0T, 100% 3.0T, 30%25T •100%250T (at PDP Module Full white screen, AC 100V) → Condition : Max Input Wattage 340W Under
Withstanding Test	10mA ↓	1.5kV(Live/Neutral/FG) for 60 sec. 3.0kV(Live/Neutral~Secondary Signal Line) for 60 sec.
Leakage current	Under 0.5mA rms (UL6500) and 0.7mA peak(IEC60065)	<ul style="list-style-type: none"> • AC 100V ~ 240V • Any load

Product Specification of 42X3 SANKEN PSU

7. Input/Output pin assignment & specification

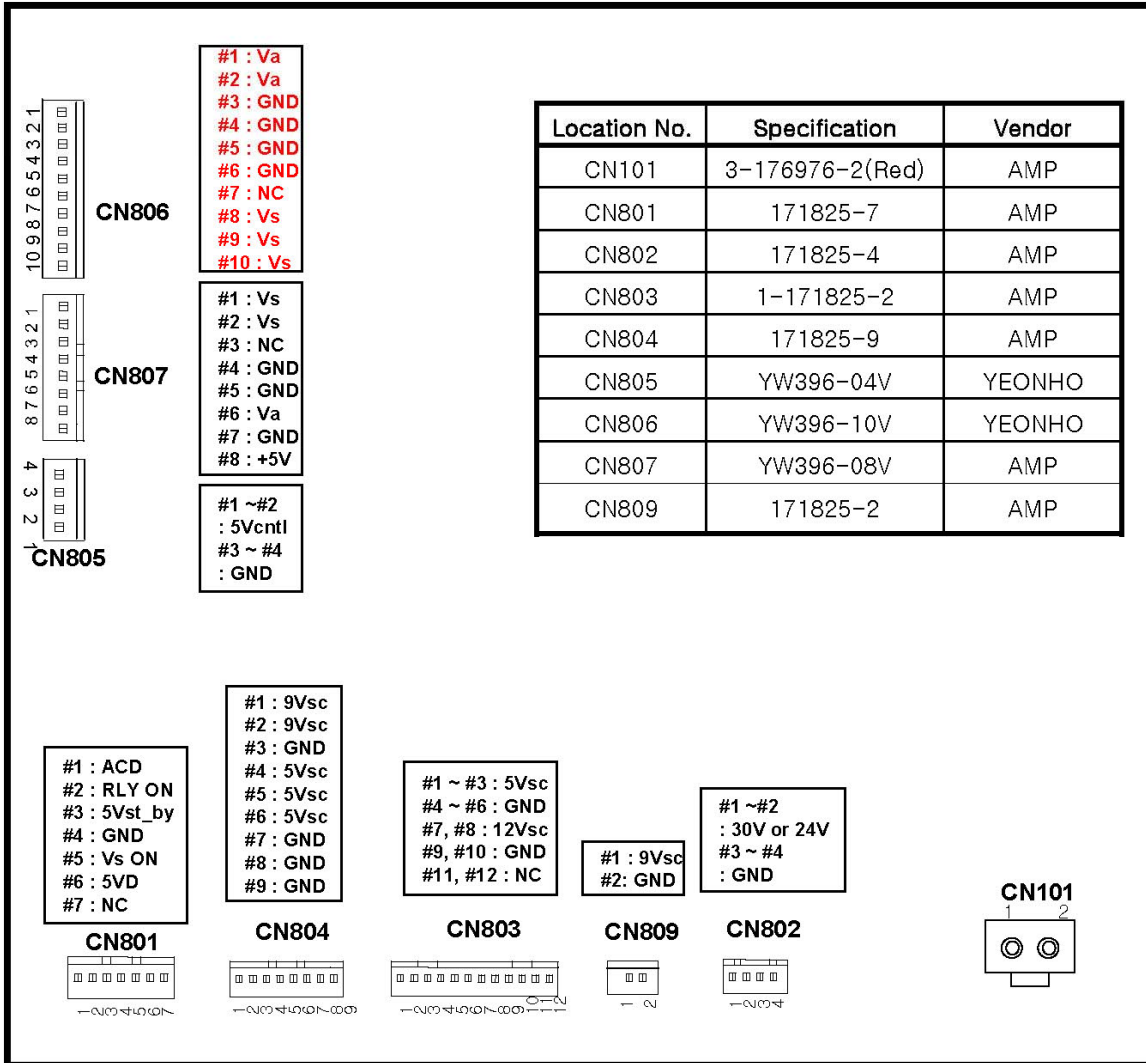

12. Bar Code Label & Safety Mark Position

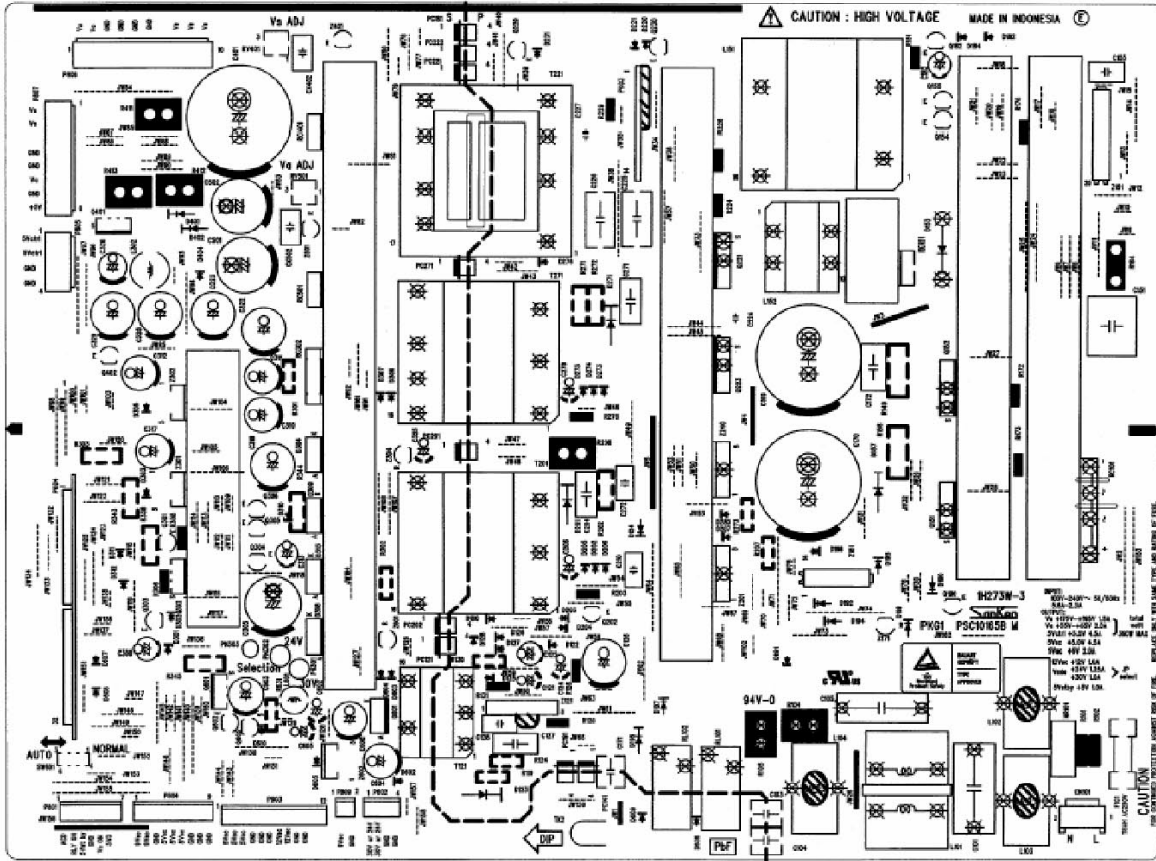

Bar Code Label

Safety Mark



Part Number,
PSU Ass'y Rev.

Serial Number

Product Specification of 42X3 SANKEN PSU

3. Output Specification

3.1 Output Voltage & Load Condition

	Output Name	Output Typical (V)	Variable Voltage Range(V)	Voltage Tolerance (%)	Output Current(A)		*2Ripple & Noise (Vp-p)
					Min.	Max.	
VSC Board (Signal Interface)	5V Stand_by	5.0	-	±5	0.03	1.0	100mVp-p
	5Vsc	5.0	-	±5	0.5	4.5	200mVp-p
	9Vsc	9	-	±5	0	2.0	100mVp-p
	12Vsc	12	-	±5	0	1.0	200mVp-p
	Vaudio (selectable)	24 30	- -	±12 ±12	0 0	1.25 1.0	500mVp-p 500mVp-p
*1PDP Module	5Vctrl	5.0	-	±5	0.5	4.5	200mVp-p
	Va	60	±5	±1	0.005	2.0	300mVp-p
	Vs	180	-5, +15	±1	0.1	1.5	500mVp-p

***1. Max. Output Power below 360W For PDP Module**

***2. Ripple & Noise measurement method**

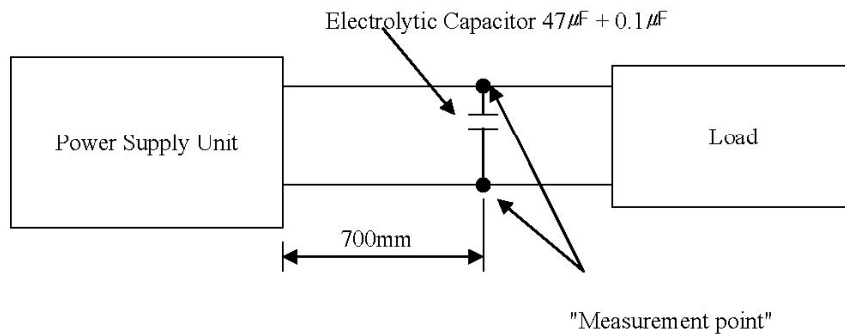

Product Specification of 42X3 SANKEN PSU

7. Input/Output pin assignment & specification

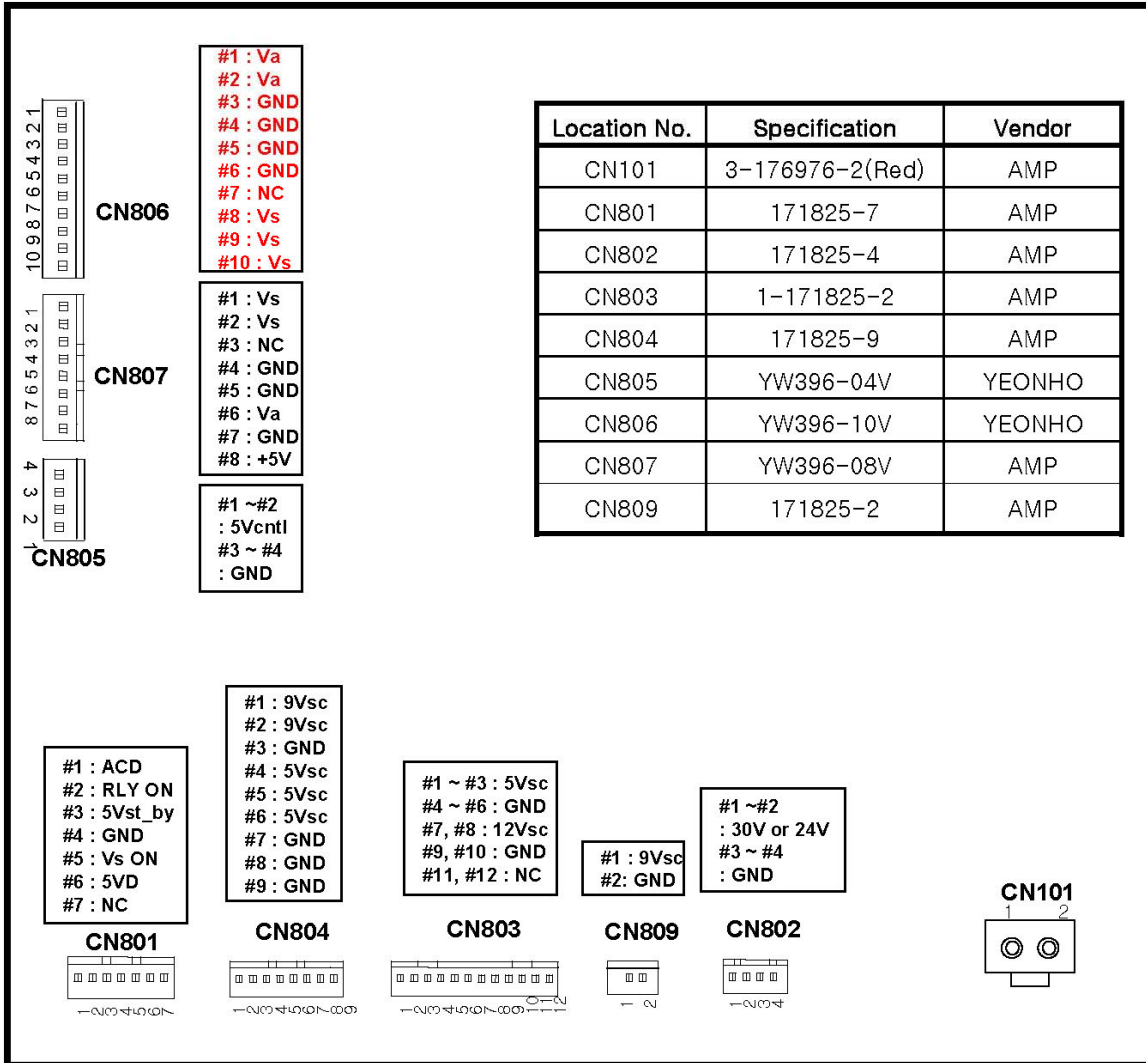

Location No.	Specification	Vendor
CN101	3-176976-2(Red)	AMP
CN801	171825-7	AMP
CN802	171825-4	AMP
CN803	1-171825-2	AMP
CN804	171825-9	AMP
CN805	YW396-04V	YEONHO
CN806	YW396-10V	YEONHO
CN807	YW396-08V	AMP
CN809	171825-2	AMP

8. Adjustment detail

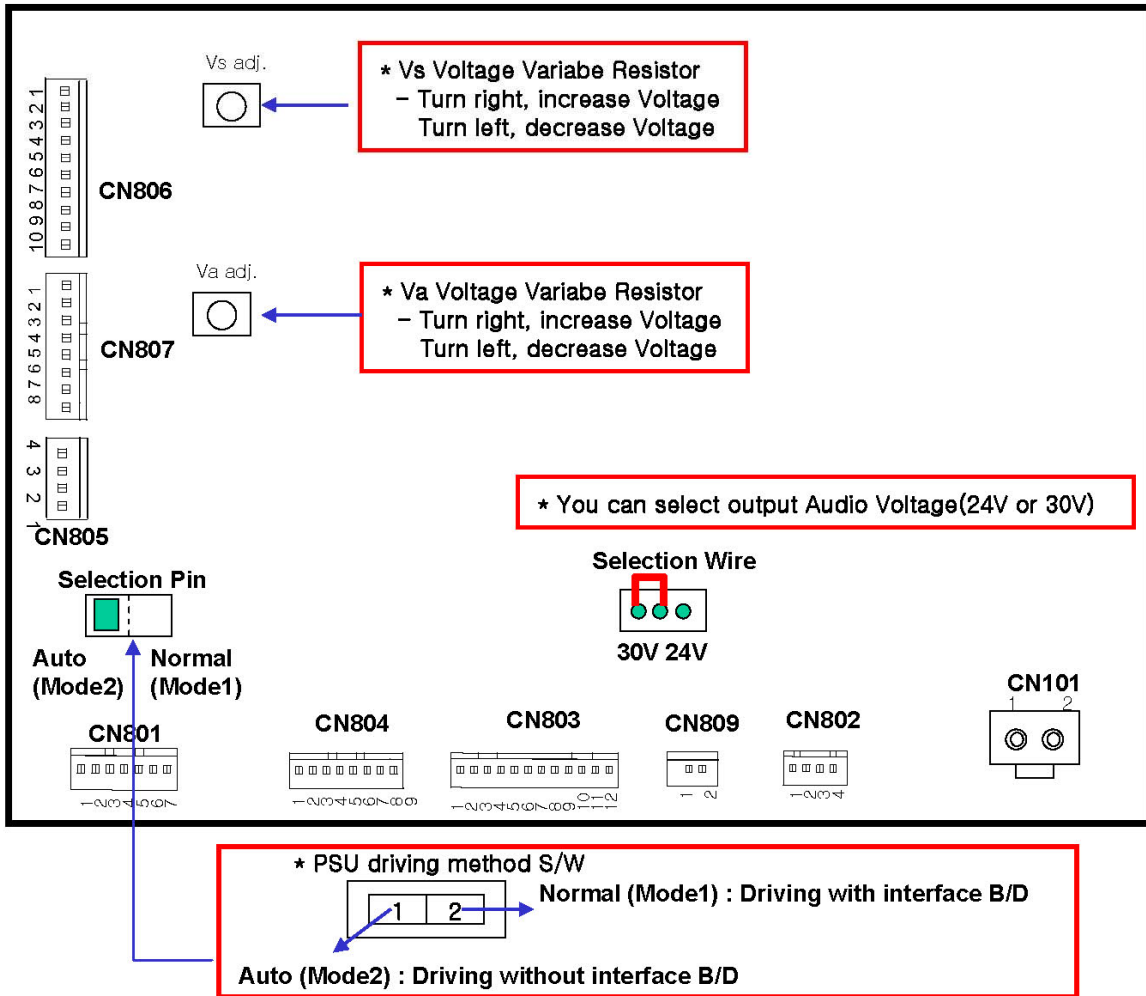

Product Specification of 42X3 SANKEN PSU

9. PSU Assembly dimension

: 329(W) × 245(L) × 40(H) mm

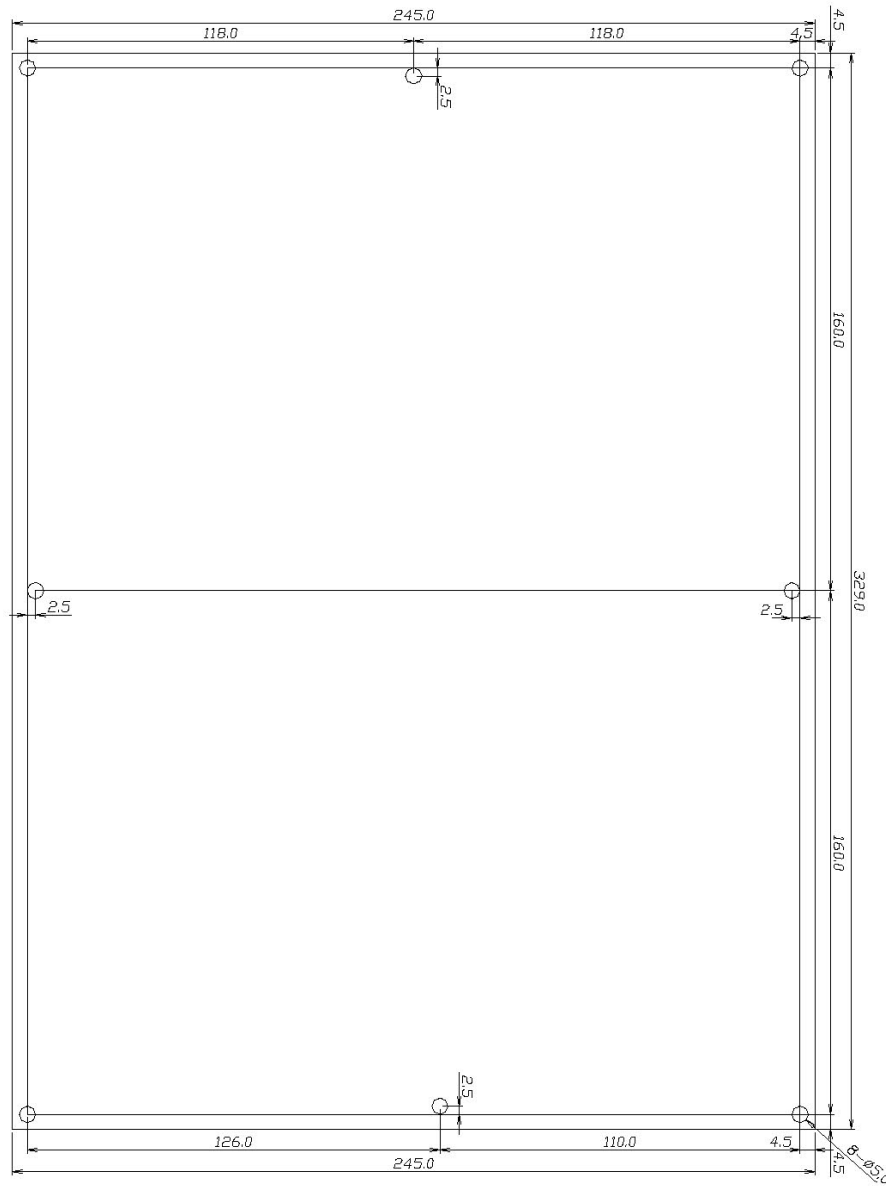

Product Specification of 42X3 SANKEN PSU

10. Noise Filter(P/N 3141Q00101B)

=> Vender : DIT / HANG SEONG

00E0001P1E

PART NO.	PART NAME	L1	L2	REMARK
3141Q00300A	Noise Filter Ass'y	600	280	
3141Q00300B	Noise Filter Ass'y	400	150	

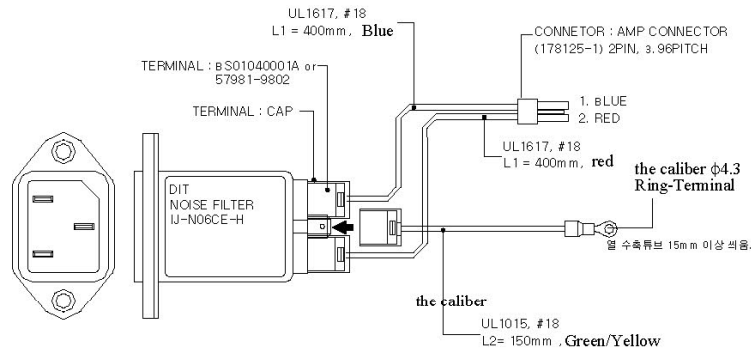

CHANGE CONTENTS					CHANGE REASON	
DATE	BY	UNIT	CHK	3rd Angle Projection	Noise Filter Ass'y	
DRAWN	DESIGN	CHECKED	APPROVED	DRAWING NAME	(42,50 MODEL)	
				Registered drawing 100-100	DRAWING NO.	3141Q00300

Product Specification of 42X3 SANKEN PSU

11. Connector Ass'y (Vender : HANG SEONG)

Harness for Connector CN 807 (from PSU to Z-Board : 6631Q39035A)

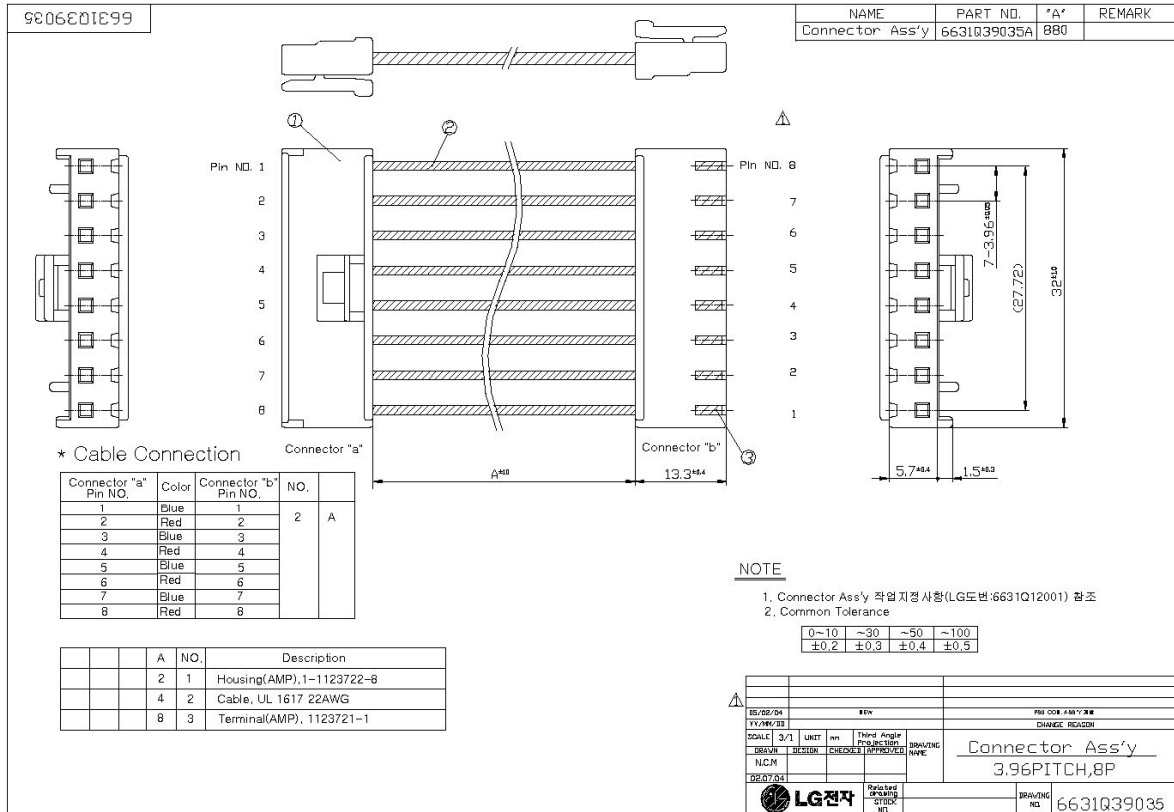

Product Specification of 42X3 SANKEN PSU

Harness for Connector CN 805 & CN806 (6631Q39022C)

220601099

6631Q39022

PART NO.	PART NAME	*A*	REMARK
6631Q39022A	Connector Ass'y	500	
6631Q39022B	Connector Ass'y	150	
6631Q39022C	Connector Ass'y	220	

Pin No. 9
8
7
6
5
4
3
2
1

Connector 'a'

13.3mm

Connector 'b'

Connector 'c'

13.3mm

15.7mm

2.5mm

*** Cable Connection**

Connector 'a' Pin No.	Color	Connector 'b' Pin No.	NO.	
1	Red	2	2	A, B
2	Black	4		
3	Blue	1		
4	Black	4		
5	Black	5		
6	Black	6		
7				
8	Red	9		
9	Red	10		

B	A	NO.	Description
1	1	1	Housing (AMP), 1-1128722-9
9	8	2	Terminal (AMP), 1128721-1
9	8	3	Cable, UL1007 18AWG
1	1	4	Housing (AMP), 1128722-D
9	9	5	Terminal, 1122721-1
1	1	6	Housing (AMP), 1-1128722-4

NOTE

1. Connector Ass'y 구입 시경사형(LG도번호 6631Q12001) 참조

2. Common Tolerance

0~10	~30	~50	~100
±0.2	±0.3	±0.4	±0.5

LG전자 LG ELECTRONICS LG ELECTRONICS	Connector Ass'y (3.9PITCH, 9P)	PART NO. 6631Q39022
--	-----------------------------------	---------------------

12. Bar Code Label & Safety Mark Position

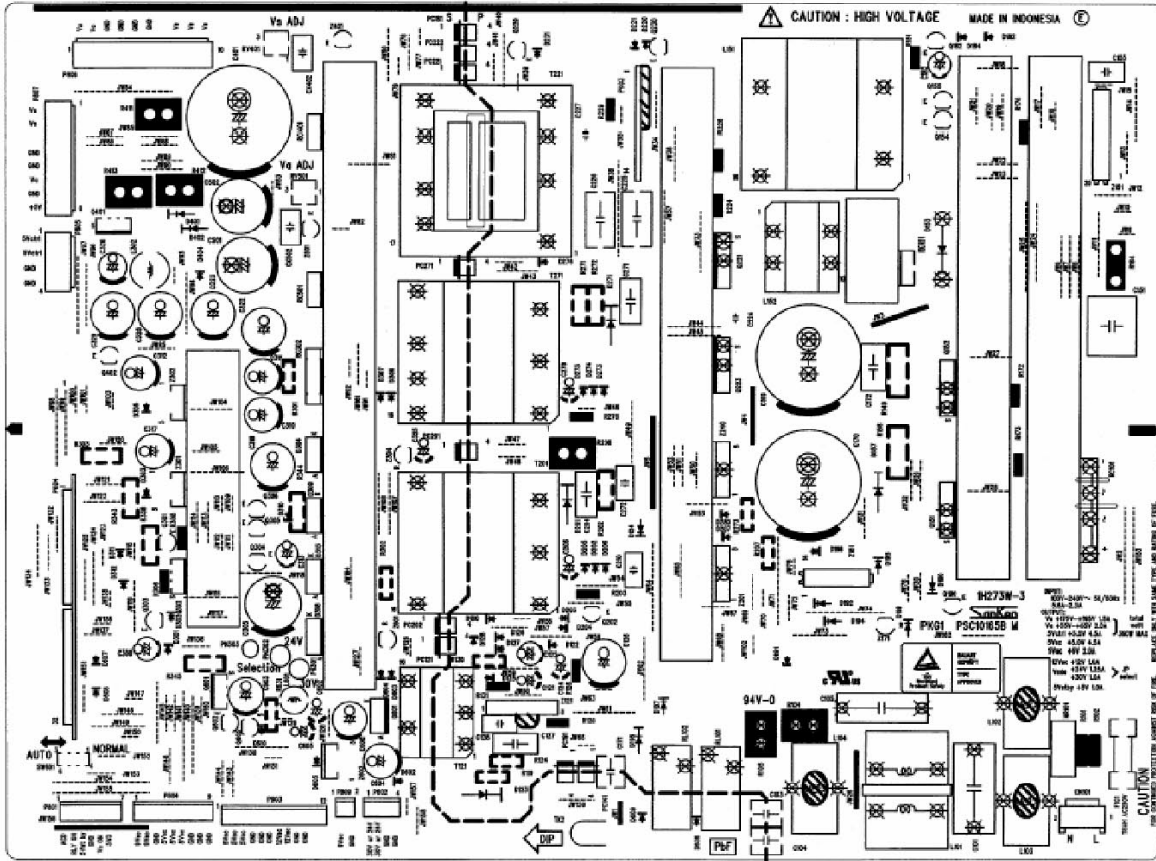

Bar Code Label

Safety Mark



Part Number,
PSU Ass'y Rev.

Serial Number

Spare Part List

PDP4273M1

Item	Part Number	Part Description	Usage / unit	Unit	Key/Spare
1>	PDP421DMIA1LS-B01	AKAI PDP421D (PDP4273M1) COSTDOWN W/O WINDOW S- MT8202/42LGX3 120V/60HZ USA MONITOR			
	510-421D11-04AK	CARTON BOX AKAI ENG PDP4273M1(COST DOWN)(S- MT8202) LGX3 PANEL USA K	1.000000	Piece	K
2>	518-421D01-01K	BOTTOM BOX 421D K	1.000000	Piece	K
3>	580-421D2A-01AP	IB E FOR AKAI PDP42HMD NO PIP (A5) LGX3 S-MT8202 USA	1.000000	Piece	K
4>	E7501-056002	REMOTE CONTROL K001 AKAI 34KEYS MT8202 PDP MONITOR W/ O PIP USA BLACK	1.000000	SET	K
5>	771E421D02-02	MAIN PCB ASSY S-MT8202(LG/ MONITOR) USA NEW	1.000000	SET	K
6>	200-42D102-SMK11A	FRONT CABINET BLACK W/AKAI (W/O BBE & HDMI SILK) ENG 421D (S-PW181) 4225M A	1.000000	Piece	S
7>	231-BP0401-01AR	STAND COVER BP04 SILVER R	1.000000	Piece	S
8>	244-34B811-01	GIFT BOX HANDLE 34B8	2.000000	Piece	S
9>	277-46SD01-03S	FUNCTION KNOB BLACK(SA-598) S	1.000000	Piece	S
10>	300-421D01-02C	POLYFOAM TOP 421D	1.000000	Piece	S
11>	300-421D02-02C	POLYFOAM BOTTOM 421D	1.000000	Piece	S
12>	310-041104-01V	POLYBAG 4"X11"X0.04 AV	1.000000	Piece	S
13>	310-111404-07V	POLYBAG 11"X14"X0.04 FV	1.000000	Piece	S
14>	310-504505-01T	POLYBAG 50"X45"X0.5MM W/MU/ TI LANGUAGE WARING &RECYCLE &HOLE	1.000000	Piece	S
15>	329-053010-70	SPONGE 530X10X7.0MM W/ ADHESIVE	2.000000	Piece	S
16>	329-095510-70	SPONGE 955X10X7.0MM W/ ADHESIVE	2.000000	Piece	S
17>	361-150208-01	CABINET TIE 150X2.0X0.8MM	1.000000	Piece	S
18>	370-42D102-01	PAD CORD SPONG FOR SPK	1.000000	Piece	S

Spare Part List

PDP4273M1

19>	384-421D01-01AH	PVC FUNCTION TERMINAL SHEET (GENERAL GLUE) FOR 421D (S-MT8202) W/SPK TERMINAL	1.000000	Piece	S
20>	384-421D01-01BH	PVC FUNCTION TERMINAL SHEET (NITTO GLUE) FOR 421D(S-MT8202)W/SPK TERMINAL	1.000000	Piece	S
21>	387-421D02-01AH	MODEL PLATE(GENERAL GLUE) AKAI ENG PDP4273M1(S-MT8202) LGX3 USA H	1.000000	Piece	S
22>	387-421D02-01BH	MODEL PLATE(NITTO GLUE) AKAI ENG PDP4273M1 (S-MT8202)	1.000000	Piece	S
23>	388-42D103-01H	CAUTION PLATE ENG 42D1 H	1.000000	Piece	S
24>	388-42SD01-01	PC SHEET FOR KEY PCB	1.000000	Piece	S
25>	402-42D10B-01S	BACK COVER 42HMD	1.000000	Piece	S
26>	426-421D01-01S	PATCH FOR LGE 421D	4.000000	Piece	S
27>	436-421D08-01S	TERMINAL SHEET FOR MT8202 MONITOR	1.000000	Piece	S
28>	481-421D01-01S	SHIELD BOX FOR MT8202 MONITOR	1.000000	Piece	S
29>	512-421D01-01	SHEET 1182X1316	.666700	Piece	S
30>	553-002007-25B	AL SHIELD GASKET 20X7X2.5MM W/CONDUCTIVE ADHESIVE	6.000000	Piece	S
31>	553-005007-10B	AL SHIELD GASKET 50X7X1.0MM W/CONDUCTIVE ADHESIVE	1.000000	Piece	S
32>	553-006007-25B	AL SHIELD GASKET 60X7X2.5MM W/CONDUCTIVE ADHESIVE	4.000000	Piece	S
33>	553-007007-10B	AL SHIELD GASKET 70X7X1.0 W/ CONDUCTIVE ADHESIVE	3.000000	Piece	S
34>	553-008007-10B	AL SHIELD GASKET 80X7X1.0 W/ CONDUCTIVE ADHESIVE	8.000000	Piece	S
35>	553-009507-10B	AL SHIELD GASKET 95X7X1.0 W/ CONDUCTIVE ADHESIVE	3.000000	Piece	S
36>	553-011007-25B	AL SHIELD GASKET 110X7X2.5MM W/CONDUCTIVE ADHESIVE	4.000000	Piece	S
37>	553-012507-25B	AL SHIELD GASKET 125X7X2.5MM W/CONDUCTIVE ADHESIVE	8.000000	Piece	S

Spare Part List

PDP4273M1

38>	553-013507-10B	AL SHIELD GASKET 135X7X1.0 W/ CONDUCTIVE ADHESIVE	2.000000	Piece	S
39>	553-020007-25B	AL SHIELD GASKET 200X7X2.5MM W/CONDUCTIVE ADHESIVE	4.000000	Piece	S
40>	553-056009-35B	AL SHIELD GASKET 560X9X3.5 W/ CONDUCTIVE ADHESIVE	2.000000	Piece	S
41>	553-095009-35B	AL SHIELD GASKET 950X9X3.5 W/ CONDUCTIVE ADHESIVE	2.000000	Piece	S
42>	554-030030-01B	AL SHIELD PLATE 30X30MM W/ CONDUCTIVE ADHESIVE	1.000000	Piece	S
43>	563-119-	SERIAL NO. LABEL	1.000000	Piece	S
44>	568-P46T02-02	WARNING LB ENG 42SF NIL	1.000000	Piece	S
45>	579-421D01-07AP	BAR CODE LABEL(W/SERIAL NO) ENG PDP4273M1(COST DOWN) USA P	2.000000	Piece	S
46>	579-42D102-09	SERIAL NO/BAR CODE LABEL 42D1	1.000000	Piece	S
47>	579-42D105-01	PROTECTIVE EARTH LABEL FOR ESA 42TD1	1.000000	Piece	S
48>	590-421D01-08AP	WARRANTY CARD AKAI ENG PDP4273M1(COST DOWN) USA P	1.000000	Piece	S
49>	593-421D01-12AP	AKAI INSERTION CARD ENG PDP4273M1(COST DOWN) (S- MT8202) USA P	1.000000	Piece	S
50>	844-421D11-01	WOODEN PALLET 1180X1110X116MM	.333300	Piece	S
51>	900-420204-01A	DISPLAY FILTER 42" SSC FOR LG 972X560X3.2 (L6-COATING TYPE)	1.000000	Piece	S
52>	E3301-028005	TERMINAL PUSH WP4-15B	1.000000	Piece	S
53>	E3404-157004	AC CORD UL 1.88M (YY-3/ST3 YUNBIAO)	1.000000	Piece	S
54>	E3461-000103	WIRE WF FLAT ASSY P2.5 5P/3P +3P L=360 FOR SPK W/EMI	1.000000	Piece	S
55>	E3461-000105	WIRE WF FLAT ASSY 5V/9V AMP_P2.5 9P/10+11P L=200/270 FOR 42LGX3 MT8202	1.000000	Piece	S
56>	E3461-000106	WIRE WF FLAT ASSY 5VSB AMP_P2.5 7P/7P L=240 FOR 42LGX3 MT8202 W/O EMI	1.000000	Piece	S

Spare Part List

PDP4273M1

57>	E3461-000109	WIRE WF FLAT ASSY P2.5 4P L=210 W/O EMI	1.000000	Piece	S
58>	E3471-000064	WIRE WS SHIELD ASSY LVDS P1.25 30P/31P L=300 FOR 42LGX3 MT8202	1.000000	Piece	S
59>	E6205-42LD03	DISPLAY PDP42" LG-42X3 (XGA)	1.000000	Piece	S
60>	E7301-010002	BATTERY AAA R03P1.5V <2>	2.000000	Piece	S
61>	771B421D01-02	IR RECEIVE PCB ASS'Y MT8202 FOR PDP42HMD	.000000	SET	S
62>	771K421D01-02	KEY PCB ASS'Y MT8202 FOR PDP42HMD	1.000000	SET	S
63>	771W421D01-02	CONNECTER PCB ASSY FOR REMOTE	1.000000	SET	S
64>	786-421D07-01	EXTERNAL SPK ASS'Y FOR W/ WINDOW SILVER 12 OHM 5W	1.000000	SET	S

If you forget your V-Chip Password

- Omnipotence V-Chip Password: 8202.

Using the "Change Password" item

- ❶ When enter the "V-Chip" menu, select "Change Password".
- ❷ Press ▲ or ▼ button to highlight the "Change Password" item.
- ❸ Press Enter button to confirm and pop up a menu.

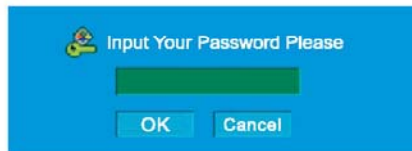

- ❹ Use 0~9 buttons input the omnipotence password(8202), then Press Enter button to enter and pop up a menu.



- ❺ Use 0~9 buttons input your new password.
- ❻ Press ▼ button to move to confirm blank.
- ❼ Use 0~9 buttons input your new password again.
- ❽ Press Enter button to confirm

-Suggest: Change to your familiar Password again.